

**FATIGUE TECHNOLOGY INC.
OPERATIONS, MAINTENANCE, AND REPAIR MANUAL**

**FT-20
Portable PowerPak**

**FTI Part #2720-015, Log #01212
Revision M**

April 15, 2022

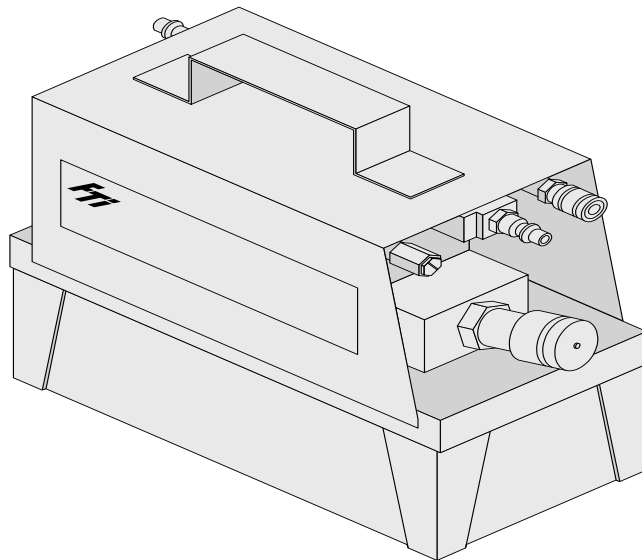

Fatigue Technology Inc. (FTI) is a world-leading aerospace engineering and manufacturing company. FTI pioneered cold expansion technology (which provides solutions to fatigue problems associated with holes in metal structures) back in 1969 and has advanced this science to develop innovative bushing and fastener products. These proprietary products and associated tooling may be covered by patents or agreements owned by, or exclusively licensed to Fatigue Technology Inc. Use of tooling procured from other than a licensed source may constitute patent infringement.

The detailed tooling information in this manual was compiled and written by FTI. The tooling was designed specifically for use with FTI's Cold Expansion Systems. FTI cannot be held responsible for damage or injury as a result of operating this equipment if it is used for other than the process intended, with any other tooling not provided by FTI, or not used in accordance with the instructions contained in this manual. To avoid personal injury, please observe all safety precautions and instructions. If you have any questions about the use or serviceability of this equipment, please contact our Sales Department.

FTI's Cold Expansion systems and processes are the subject matter of one or more of the following patents: 4,809,420; 4,885,829; 4,934,170; 5,083,363; 5,096,349; 5,103,548; 5,127,254; 5,129,253; 5,218,854; 5,245,743; 5,305,627; 5,341,559; 5,380,136; 5,405,228; 5,433,100; 5,468,104; 6,077,010; 6,183,180; 6,487,767; 6,792,657; 6,990,722; 7,024,908; 1,061,276; 513,898; 692015124; 581,385; 69310828; 468,598; 69105390; 643,231; 69414946; 696,686; 785,366; 1032769; and other patents pending. These systems and processes are tooling critical and must be performed in accordance with FTI's specifications or controlling documents. To ensure proper results from FTI's cold expansion systems and to be licensed to use FTI's patented processes, it is essential that FTI's complete integrated system of tooling be purchased and utilized. The use of tooling purchased from other than a licensed supplier could jeopardize fatigue life enhancement and may constitute patent infringement.

FTI reserves the right to change the specifications or configurations of tooling detailed in this manual as part of its ongoing technical and product information program. Should inconsistencies occur between your tooling and this manual, please contact our Sales Department.

ABOUT FATIGUE TECHNOLOGY INC.

Fatigue Technology Inc. (FTI) has provided innovative solutions to the aerospace industry since 1969. Our products are used worldwide to reduce manufacturing and maintenance flow time and costs.

The FTI staff of professionals provides a full range of support services including:

- Application engineering
- Detailed project planning, implementation, and management
- On-site assistance, including training and tool room setup

The Sales Department is always available to assist with special fatigue enhancement requirements. Please contact FTI with questions at any time.

TABLE OF CONTENTS

SECTION	DESCRIPTION	PAGE
1.0	Introduction.....	1
1.1	About the FT-20 PowerPak	1
1.2	Identification of FT-20 Series PowerPaks	1
1.3	General Specifications	2
2.0	Safety	3
3.0	FT-20 Operating Instructions.....	5
3.1	Hydraulic PowerPak Setup Procedure and Operation	5
3.2	Actuation of PowerPak	6
4.0	FT-20 Maintenance.....	7
4.1	General Cleaning	7
4.2	Checking Hydraulic Fluid Level.....	7
4.3	Filling Hydraulic Fluid Reservoir.....	7
4.4	Changing the Hydraulic Fluid.....	8
4.5	Lubrication and Air Requirements.....	8
5.0	Troubleshooting.....	9
5.1	Pump Will Not Start or Stop.....	9
5.2	Mandrel Will Not Pull Back into the Barrel of the Puller Unit	10
5.3	PowerPak Builds Hydraulic Pressure but Cannot Maintain Pressure	11
5.4	PowerPak Will Not Build Full Pressure	12
5.5	Air Rushes Out around the Trigger.....	12
5.6	Puller Retracts, But Will Not Return	13
5.7	PowerPak Will Not Stop When Trigger is Released	13
6.0	FT-20A and FT-20-4K Illustrated Parts Breakdown	14
6.1	External Fittings: FT-20A Side View; Parts List.....	14
6.2	External Fittings: FT-20A Top View; Parts List	15
6.3	Basic Pump Assembly: FT-20A Front View; Parts List.....	16
6.4	Basic Pump Assembly: FT-20A Top View; Parts List.....	17
7.0	FT-20 Illustrated Parts Breakdown.....	18
7.1	External Fittings: FT-20 Side View; Parts List.....	18
7.2	External Fittings: FT-20 Top View; Parts List	19
7.3	Basic Pump Assembly: FT-20 Front View; Parts List.....	20
7.4	Basic Pump Assembly: FT-20 Top View; Parts List.....	21
8.0	Safety Data Sheet.....	22

TABLE OF CONTENTS (CONTINUED)

SECTION	DESCRIPTION	PAGE
FIGURES		
Figure 2.0-1	Safety Stickers	3
Figure 3.1-1	FT-20 PowerPak	5
Figure 5.6-1	Enerpac CT-604 Pressure Relief Tool	13
Figure 6.1-1	FT-20A External Fittings; Side View	14
Figure 6.2-1	FT-20A External Fittings; Top View	15
Figure 6.3-1	FT-20A Basic Pump Assembly; Front View	16
Figure 6.4-1	FT-20A Basic Pump Assembly; Top View	17
Figure 7.1-1	FT-20 External Fittings; Side View	18
Figure 7.2-1	FT-20 External Fittings; Top View	19
Figure 7.3-1	FT-20 Basic Pump Assembly; Front View	20
Figure 7.4-1	FT-20 Basic Pump Assembly; Top View	21

SECTION 1.0: INTRODUCTION

This instruction manual contains information on the operation and maintenance of the FT-20 portable hydraulic PowerPak. To obtain optimum performance and many years of trouble-free service, operate the PowerPak properly and follow maintenance procedures carefully.

Read this manual before operating the PowerPak and retain it for future reference. If requested, FTI will provide this manual in the language of the end-user.

1.1 ABOUT THE FT-20 POWERPAK

The FT-20 is a portable PowerPak that supports the FTI system of tooling. Because of its small size and light weight, the FT-20 is particularly useful for work in areas with difficult or restricted access. It may be used to operate FTI hydraulic puller units in the Little Brute and Medium Brute family. The FT-20 may also be used with the Big Brute (BB-30) puller unit, though its operation will be slow when compared to the larger FT-200 PowerPak.

The FT-20 contains an air operated hydraulic pump that generates up to 10,000 pounds per square inch (psi) hydraulic pressure (4,000 psi for the FT-20-4K). The air motor is driven by compressed air at 90 to 120 psi and 20 cubic feet per minute (cfm) flow through a 3/8-inch minimum inside diameter air hose. See Section 6.0 for PowerPak configuration and schematics.

NOTE: The FT-20 is shipped with hydraulic fluid already in the unit. The FT-20 is shipped with a non-vented cap on the reservoir. This must be replaced with the supplied vented cap and dipstick prior to operation. If there is a need to fill the FT-20 with hydraulic fluid or drain the fluid for reshipment, please refer to Section 4.3 for instructions.

1.2 IDENTIFICATION OF FT-20 SERIES POWERPAKS

There are three different models in the FT-20 series. The primary identification method is identified on the decal on the side of the manifold.

- FT-20 is the original pump.
- FT-20A is an updated model. This is the most common model.
- FT-20-4K is a FT-20A with a reduced pressure setting of 4,000 psi.

1.3 GENERAL SPECIFICATIONS

Dimensions:	In the box: 10" x 5.1" x 10.2" Operational: 10" x 5" x 9.7"
Weight:.....	15.5 lbs. dry; 18.25 lbs. shipping weight
Operating Hydraulic Pressure:	10,000 psi maximum; 4,000 psi maximum for the FT-20-4K
Air Supply:.....	90 to 120 psi, clean and dry; 20 cfm flow minimum
Air Supply Hose:.....	3/8" Inside Diameter
Air Lubricator Fluid:.....	5-20w synthetic oil
Hydraulic Fluid Capacity:.....	1/2 US gallons
Hydraulic Fluid Characteristics:	Power Team Hydraulic Oil ASTM 215
Viscosity Index:	100 minimum
Viscosity:	48 SUS at 210°F, 215 SUS at 100°F
Specific Gravity at 60°F:	0.88
Flash Point, degrees:	400°F
Fire Point, degrees:	430°F
Pour Point, degrees:	-30°F
Aniline Point, degrees:.....	210°F/220°F
Paraffinic Base Color:.....	ASTM 2.0
Suitable Substitutes for Hydraulic Fluid:.....	Power Team hydraulic oil #9637; Enerpac Hydraulic Oil HF-100; or US MIL-SPEC #5606; or MIL-PRF-83282; or meets ISO 46; or AeroShell 41; or ASTM 215; FTI Part Number 1045-154
Suitable Puller Units:	All Little Brute Puller Units, MB-30, MB-70, BB-30
Noise Reading	85.2 to 89.8 dBA

SECTION 2.0: SAFETY

Consult the appropriate puller unit manual for safety precautions before installing a puller unit onto a PowerPak.

When used in accordance with these instructions, the FT-20 is safe and easy to use. All general safety precautions associated with hydraulic and pneumatically operated power tools should be observed. Many of these are noted in this section. Ultimately, the operator is responsible for personal safety; however, the following general safety precautions should be observed. Also see Figure 2.0-1.

CAUTION: Set the FT-20 PowerPak on a level surface. If the surface is out of plane, there is a risk of the FT-20 PowerPak unit vibrating off the surface.

Read manual before using

Always wear eye protection

Always wear ear protection



**Figure 2.0-1
Safety Stickers**

1. Wear eye and ear protection when operating the FT-20.
2. Disconnect the air supply when:
 - Maintenance is to be performed.
 - Hydraulic hose is disconnected.
 - PowerPak is not in use.
3. In the event of a ruptured or leaking hydraulic hose, IMMEDIATELY RELEASE THE TRIGGER AND DISCONNECT THE AIR LINE from the PowerPak at the air input. Never use your hands to grasp a leaking hose under pressure. The force of escaping hydraulic fluid can cause serious injury.
4. DO NOT attempt to disconnect the hydraulic hose while the pump is running.
5. DO NOT expose hoses to potential hazards, such as extreme heat or cold, sharp surfaces, heavy impact, or vehicular traffic.
6. DO NOT allow hoses to kink, twist, curl, or bend so tightly that the oil flow within the hose is blocked or reduced.
7. Periodically inspect the hose for wear or damage which could cause premature failure of the hose and possibly result in injury.
8. Hose material and coupler seals must be compatible with the hydraulic fluid used.

9. Hoses must not come in contact with toxic materials, such as creosote-impregnated objects and some paints. Keep clean and never paint couplers or hoses. Hose deterioration due to chemical degradation may cause the hose to fail under pressure.
10. DO NOT exceed the hydraulic pressure (psi) rating recommended or tamper with the internal high-pressure relief valve. Creating pressure beyond rated capacities may result in personal injury and/or damage to the PowerPak.
11. DO NOT exceed the recommended air pressure of 90 to 120 psi (6.2 to 8.3 bar).
12. Before operating the pump, tighten all hose connections using the proper tools. Do not overtighten the connections. Connections need only be tightened securely and leak-free. Overtightening may cause premature thread failure, or high-pressure fittings to split at pressures lower than their rated capacities.
13. Periodically pump clean oil through the entire length of the hose, then pressurize the hose and check for leaks at the crimped connectors, between the hose material and the fitting, and between the fitting and coupler.
14. Before replenishing the oil level, retract all cylinders to prevent overfilling the pump reservoir. Overfilling may cause personal injury due to excess reservoir pressure created when the cylinders are retracted.
15. **Do not use the hose to move attached equipment.** Stress may damage the hose and cause personal injury.
16. DO NOT use in potentially explosive atmospheres.

IMPORTANT: FTI completed a risk assessment on this unit at our factory. Any modifications done by a third party or the final user are excluded from that risk assessment. As a result, modifications done by a third party or the final user nullify the CE marking.

SECTION 3.0: FT-20 OPERATING INSTRUCTIONS

Become familiar with these instructions before operating the FT-20.

3.1 HYDRAULIC POWERPAK SETUP PROCEDURE AND OPERATION

See Section 6.0 for parts identification.

Conduct the following procedures BEFORE actuation:

1. Remove the pipe plug and attach the main air hose quick disconnect to the air inlet fitting. The air supply must be clean and dry, and 90 to 120 psi at a minimum flow of 20 cfm.

NOTE: Clean the top plate of the pump before removing the filler cap and dipstick to prevent contaminants from entering the oil supply.

2. Remove the shipping plug from the reservoir fill port and replace with the supplied vented cap.
3. **The fill line on the reservoir is 5/16 inch from the top.** Visually inspect the oil level in the reservoir. When operating, make sure the reservoir vented cap is in place. The oil level should be within 5/16 inch of the filler plug; if the pump is to be operated with the reservoir unvented, the oil level should be 3/4 inch from the filler plug. If the oil level is low, replenish the hydraulic fluid per the instructions in Section 4.3.
4. Inspect all threads and fittings for signs of wear or damage and replace them if necessary.
5. Uncoil the hose assembly from the puller unit to be used and inspect all threads, couplings, and hoses for damage and degradation. Replace if necessary.
6. Remove the dust caps from the hydraulic fittings of the FT-20 and puller unit hose, and clean both couplers prior to connecting to prevent contaminants from entering the oil supply. Thread the hydraulic hose coupler from the puller unit to the quick hydraulic coupler of the PowerPak.

NOTE: Ensure that the couplers on both the PowerPak and hose fittings are pushed firmly together, then completely screwed together. Failure to do so will prevent the oil from returning to the pump when the trigger is released. This will cause the puller unit to stay in the retracted position.

7. Clean, then connect the two air quick disconnects from the puller unit to the coupler plug and coupler socket of the PowerPak.

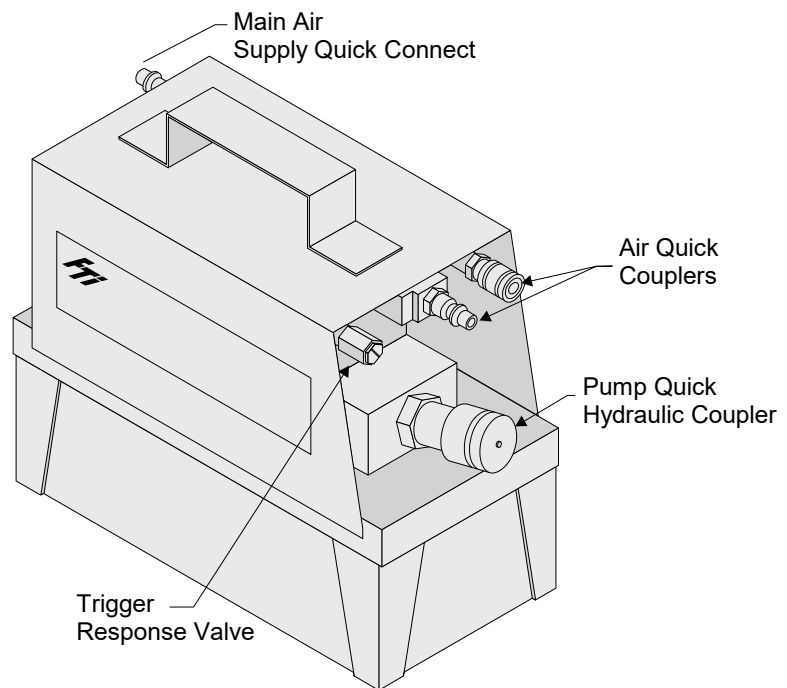

**Figure 3.1-1
FT-20 PowerPak**

CAUTION

It is suggested that an automatic air line oiler/filter be installed as close to the pump as possible. Set oiler to feed 1 to 3 drops per minute into the system. Use No. 10 SAE non-detergent oil. **NOTE: An oiler package (including gage, filter, lubricator, and fittings) is NOT included with the FT-20 but is available from FTI. Please contact our Sales Department for details.**

3.2 *ACTUATION OF POWERPAK*

CAUTION: Set the FT-20 PowerPak on a level surface. If the surface is out of plane, there is a risk of the FT-20 PowerPak unit vibrating off the surface.

1. The PowerPak is an air-driven hydraulic unit and can be activated only when connected to a FTI puller unit or remote trigger as described in Section 3.1.
2. Activate the FT-20 by depressing the trigger on the handle of the puller unit. An air logic valve opens, allowing the main air supply into the air motor which drives the hydraulic pump. Hydraulic pressure is transmitted through the hose to the cylinder of the puller unit, which then retracts the hydraulic piston.
3. Releasing the trigger allows the air logic valve to shift and air pressure in the puller unit barrel returns the puller piston to the start position.
4. If actuation fails to take place, the trigger response valve may need to be adjusted. This is done by loosening the brass nut on the trigger response valve. Connect the pump main air supply and the puller unit. Then, with the puller unit trigger depressed, adjust the pilot screw in (clockwise) or out (counterclockwise). Turning the pilot screw in makes the trigger more sensitive, while adjusting it out makes it less sensitive. Once the desired sensitivity is achieved, retighten the brass nut. Different puller units may require this valve to be readjusted.

SECTION 4.0: FT-20 MAINTENANCE

The FT-20 requires routine checking of the unit and periodic preventative maintenance to ensure safe, trouble-free operation. No special maintenance is required. The following actions are suggested.

CAUTION:
Disconnect the PowerPak from air supply before performing maintenance or repair.

4.1 GENERAL CLEANING

1. Periodically clean the outer surfaces of the FT-20 and equipment used with the FT-20.
2. When not in use, ensure that the dust cap is reinstalled on the hydraulic coupler.
3. Keep all hose connections free of metal chips, dirt, and grime.
4. Keep the breather hole in the vented filler cap and dipstick clean and unobstructed.
5. The hydraulic oil should be replaced every 200 to 500 hours of use, depending on severity of use and environmental conditions.
6. Always clean the hydraulic and air couplers prior to making connections.

4.2 CHECKING HYDRAULIC FLUID LEVEL

1. Clean the top plate, remove the filler cap and dipstick, and visually check the oil level in the reservoir after every 40 hours of use.
2. The proper oil level is within 5/16 inch of the top of the reservoir when the puller unit's mandrel is in its normal starting position (mandrel extended and trigger released). The fill line on the reservoir is 5/16 inch from the top.

4.3 FILLING HYDRAULIC FLUID RESERVOIR

1. Disconnect the puller unit from the PowerPak and the air supply when adding oil to the reservoir.
2. Clean the entire area around the vented filler cap and dipstick before removing the filler plug located to the right and slightly behind the hydraulic quick coupler.
3. Remove the filler cap and dipstick. Insert a clean funnel with a flexible tube and strain the new oil through a paper filter. If a flexible tube is not available, the pump shroud may need to be removed for access.
4. Fill with hydraulic fluid to within 5/16 inch of the top of the filler hole. The fill line on the reservoir is 5/16 inch from the top. See Section 1.3 for hydraulic fluid specifications.
5. Replace the filler cap and dipstick and make sure the breather hole in the filler cap and dipstick is open. Cycle the PowerPak (with the puller unit attached) several times, and recheck the oil level in the PowerPak reservoir.

4.4 *CHANGING THE HYDRAULIC FLUID*

1. After approximately 200 to 500 hours of use, the hydraulic fluid should be changed. The frequency of oil changes will depend upon the general working conditions, severity of use, overall cleanliness, and care given the PowerPak.
2. To drain the FT-20, remove the shroud and cover retainer screws and expose the reservoir. (If a drain plug is present, unscrew the plug and drain the oil through the port.)
3. Drain the hydraulic fluid by pouring the oil over and out one corner of the reservoir.
4. Refill the reservoir with hydraulic fluid. See Section 1.3 for hydraulic fluid specifications.
5. Replace the pump on the reservoir, torquing the cover plate retaining screws to 25/30 in-lbs. Make sure the reservoir gasket is in place.
6. Replace the shroud.

4.5 *LUBRICATION AND AIR REQUIREMENTS*

1. The air supply must be clean and dry, and provided at 90 to 120 psi. Volume must be a minimum of 20 cfm, and a 3/8-inch inside diameter air hose is recommended.
2. FTI recommends that an automatic air line filter/oiler be installed in the air inlet line as close to the PowerPak as possible. Set the oiler to feed 1 to 3 drops of oil per minute (one drop for every 50 to 75 cfm of air) into the system. Use SAE No. 10 non-detergent oil.

SECTION 5.0: TROUBLESHOOTING

This section provides some basic steps to identify possible causes of trouble, together with troubleshooting solutions. The FT-20 is a sealed unit. If there are any problems with the PowerPak which go beyond the scope of these instructions, contact Fatigue Technology Inc. or an FTI Representative who can provide you with the nearest authorized service center.

WARNING:

To prevent injuries, any repair work or troubleshooting must be done by qualified personnel familiar with this equipment. Use proper equipment and tools when troubleshooting.

IMPORTANT: Refer to the parts lists (Section 6.0) when using the Troubleshooting Guide.

PROBLEM	CAUSE	SOLUTION
5.1 PUMP WILL NOT START OR WILL NOT STOP REGARDLESS OF TRIGGER POSITION		
	<i>NOTE: This is common for new pumps or different puller unit/pump combinations.</i>	
	(a) Trigger response valve is not properly adjusted.	(a) While squeezing the trigger of the puller unit, loosen the brass nut on the trigger response valve. Adjust the valve pilot in or out until the desired sensitivity is obtained. Retighten the brass nut.
	(b) Air logic valve is stuck in position.	(b) The air logic valve is located on top of the pump just under the shroud. Remove the shroud and disassemble the valve. Remove the valve spool and inspect the O-rings and spool body. If the valve is a Versa [®] brand valve (gold body), replace the O-rings as required and remove any contaminates. If the valve is an I.S.I. brand valve (black body), the spool will most likely need to be replaced. Clean any contaminates from the valve body. Refer to Section 6.0 for valve part numbers.

PROBLEM**CAUSE****SOLUTION****5.2 MANDREL WILL NOT PULL BACK INTO THE BARREL OF THE PULLER UNIT**

- | | |
|---|--|
| (a) Inadequate air pressure or flow. | (a) Obtain air pressure at 90 to 120 psi and flow at 20 cfm with a hose diameter of 3/8-inch minimum inside diameter. |
| (b) Trigger response valve is not properly adjusted. | (b) While squeezing the trigger of puller unit, loosen the brass nut on the trigger response valve. Adjust the valve pilot in or out until the desired sensitivity is obtained. Retighten the brass nut. |
| (c) Loose oil coupling to the puller unit. | (c) Check the quick-disconnect couplings on the hose and pump. Inspect couplers to ensure that they are completely tightened. |
| (d) Oil level too low. | (d) Refer to Section 4.2, Checking Hydraulic Fluid Level. |
| (e) Hydraulic line from the puller unit is not attached to the hydraulic quick-coupler. | (e) Connect the hydraulic line to the hydraulic quick-coupler. |
| (f) Vacuum in reservoir. | (f) Check for a plugged vent in the vented filler cap and dipstick. Loosen the filler cap 1 to 2 turns. |
| (g) Flow check valve in coupler does not stay open when coupler is connected properly. | (g) Replace the coupler. |
| (h) Dirt in pump or filter plugged. | (h) The oil pick-up strainer should be cleaned; if necessary, the PowerPak should be dismantled and all parts inspected and cleaned. Replace the hydraulic oil. |
| (i) Leak in the air circuit. | (i) Ensure there are no air leaks from any fittings. Tighten fittings to eliminate the leaks. NOTE: Leaks from the puller unit trigger are acceptable. |
| (j) Relief valve or low pressure unloading valve is out of adjustment. | (j) Readjust as needed. Because this adjustment is complex, contact FTI about procedures for return or repair. |

PROBLEM**CAUSE****SOLUTION****5.3 POWERPAK BUILDS HYDRAULIC PRESSURE BUT CANNOT MAINTAIN PRESSURE****CAUTION:**

Operation of the pump motor with it lifted from the reservoir (Step 5.3c) may result in oil spray. Please shroud the assembly accordingly.

- | | |
|--|--|
| (a) Insufficient volume of air. | (a) Check the air supply. Hoses should be 3/8-inch inside diameter. |
| (b) External oil leaks. | (b) Replace leaking pipe fittings. Reseal or replace any faulty line fittings. If no oil leakage is visible, the problem may be internal. |
| (c) Pressure control valve leaks. | (c) To test for a leaking control valve lift the pump from the reservoir but keep the intake filter in the oil. Remove the drain line to see if the oil is leaking from the valve. If the control valve is not leaking, the internal check valve could be leaking. |
| (d) Piston packing or valve seats are damaged. | (d) Return the pump to FTI for repair. |

PROBLEM	CAUSE	SOLUTION
---------	-------	----------

5.4 POWERPAK WILL NOT BUILD FULL HYDRAULIC PRESSURE

- | | |
|--|---|
| (a) Inadequate air pressure or air flow. | (a) Increase air pressure and/or hose diameter. |
| (b) Faulty pressure gage. | (b) Calibrate the gage. |
| (c) External fitting leakage. | (c) Replace the leaking pipe fitting. |
| (d) Faulty internal pressure regulator. | (d) Lift the pump from the reservoir but keep the filter immersed in oil. Note the pressure reading when the relief valve begins to open. If it is functioning normally, the pressure should start to bleed off at 9,500 to 10,000 psi (4,000 psi for the FT-20-4K). |
| (e) Internal leakage in puller unit. | (e) Disconnect the puller unit. Use a different puller unit to test the PowerPak; if it builds to full pressure using a different puller unit, the first puller unit is defective. If another puller unit is unavailable, look for oil leaks and their locations. Refer to the appropriate puller unit manual for instructions. |
| (f) Leaks in the pressure valve. | (f) Clean and reseal or replace the valve. |
| (g) Piston packing or valve seats are damaged. | (g) Return the pump to FTI for repair. |

5.5 AIR RUSHES OUT AROUND THE TRIGGER OF THE PULLER UNIT WHEN ACTUATED AND PUMP DOES NOT OPERATE.

NOTE: Minor air leakage from the trigger is normal.

- | | |
|--|--|
| (a) An air line from the puller unit is not connected. | (a) Connect the air line. |
| (b) The trigger response valve is not properly adjusted. | (b) While squeezing the trigger of the puller unit, loosen the brass nut on the trigger response valve. Adjust the valve pilot in or out until the desired sensitivity is obtained. Retighten the brass nut. |
| (c) Hose fittings from the puller unit or PowerPak are reversed. | (c) Check all hose fitting configurations in the puller unit manual. |
| (d) Air logic control valve is stuck in position. | (d) Refer to 5.1 (b). |

PROBLEM	CAUSE	SOLUTION
---------	-------	----------

5.6 PULLER RETRACTS ON FIRST TRIGGER ACTUATION, BUT WILL NOT RETURN TO START POSITION.

- (a) The new puller unit requires lubrication through the piston and cylinder.
- (a) Cycle the trigger several times to introduce hydraulic fluid to the cylinder. If piston fails to return, proceed to 5.6 (b).
- (b) The hydraulic quick coupler has not been completely tightened at the PowerPak manifold. This allows the check valve in the puller unit's hydraulic quick coupler to close on the return stroke.
- (b)
 - 1) Disconnect the air supply from the FT-20.
 - 2) Disconnect the coupler from the FT-20.
 - 3) Connect Enerpac CT-604 to the coupler and bleed off hydraulic oil to relieve the build-up. Figure 5.6-1 shows the Enerpac CT-604 Pressure Relief Tool.
 - 4) Once pressure is relieved, the coupler may be tightened and reinstalled onto the PowerPak.
 - 5) Reattach the air lines to get the puller unit to return.
 - 6) Check the oil level in the PowerPak reservoir.



**Figure 5.6-1
Enerpac CT-604 Pressure Relief Tool**

5.7 POWERPAK WILL NOT STOP OPERATING WHEN TRIGGER IS RELEASED.

- (a) Puller unit retracts and will not return because hydraulic pump will not shut off, or there is a delay in PowerPak shutoff.
- (a) Trigger response valve is not properly adjusted. See 5.1 (a).
- (b) Air logic control valve is stuck in position.
- (b) See 5.1 (b).

SECTION 6.0: FT-20A AND FT-20-4K ILLUSTRATED PARTS BREAKDOWN

Note: There are three configurations of the FT-20 PowerPak: the original FT-20, the revised FT-20A, and the reduced pressure FT-20-4K. The style of pump is identified on Decal #2 in the figure below. Section 6.0 describes the FT-20A, while Section 7.0 describes the original FT-20. Use the FT-20A section for the FT-20-4K.

6.1 EXTERNAL FITTINGS: FT-20A, SIDE VIEW; PARTS LIST

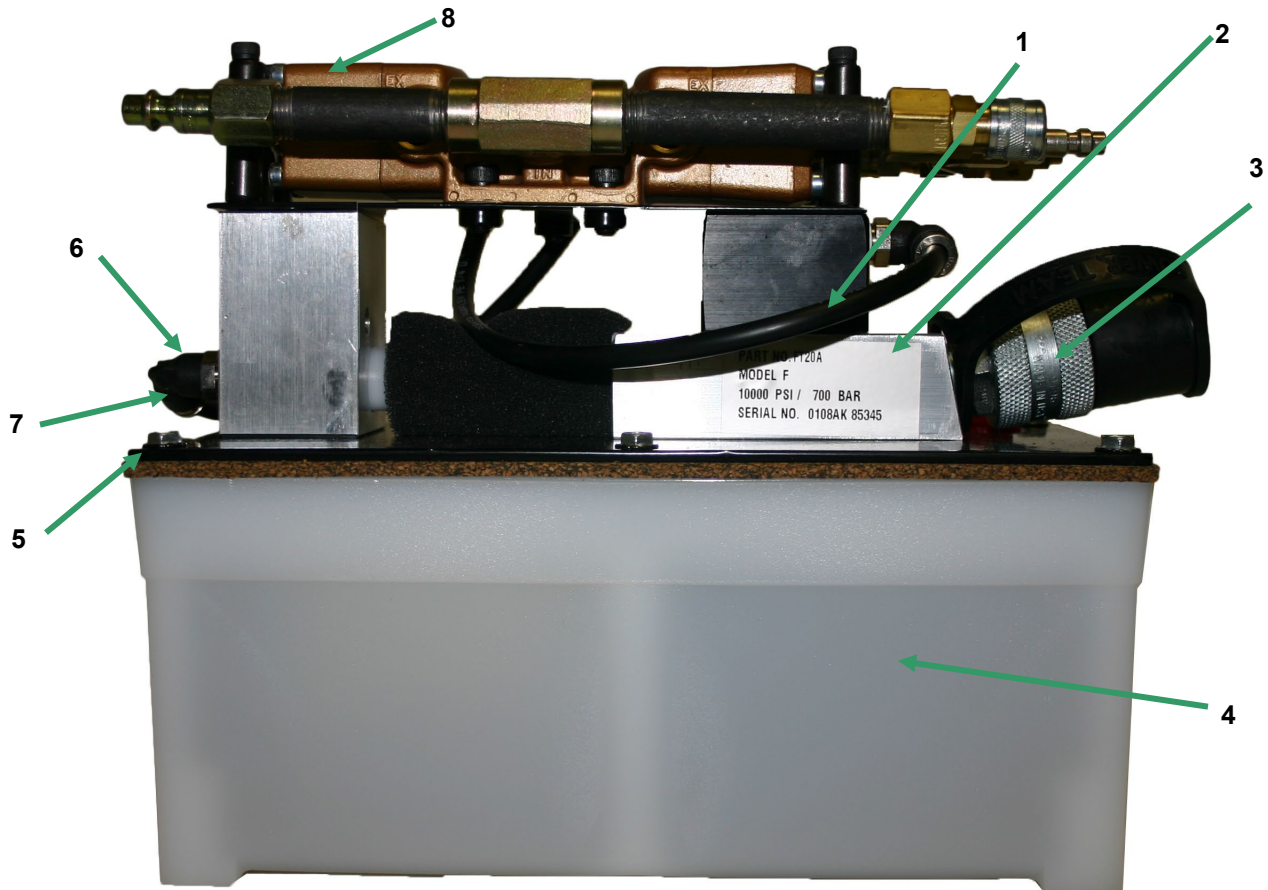

Item Number	FTI Part Number	SPX Part Number	Applicable Model No.	Number Required	Description
1	1125-003	14726 or 15883	FT-20A	0.4 foot	Tubing
2	----		FT-20A	1	Decal
3	1047-013		FT-20A	1	Hydraulic Quick Coupler
	1047-090		FT-20-4K		
4	1125-005	61243	FT-20A	1	Plastic Reservoir
5	1125-007	33853	FT-20A	1	Reservoir Gasket
6	1125-003	14726 or 15883	FT-20A	0.5 foot	Air Hose
7	1125-002	15457	FT-20A	4	90-Degree Elbow Fitting
8	1125-036	53092GY8	FT-20A	1	Shroud
--	1187-770		FT-20A	0	Pressure Relief Tool ¹

Note 1: Not included.

Figure 6.1-1
FT-20A External Fittings; Side View

FT-20A

6.2 EXTERNAL FITTINGS: FT-20A, TOP VIEW; PARTS LIST

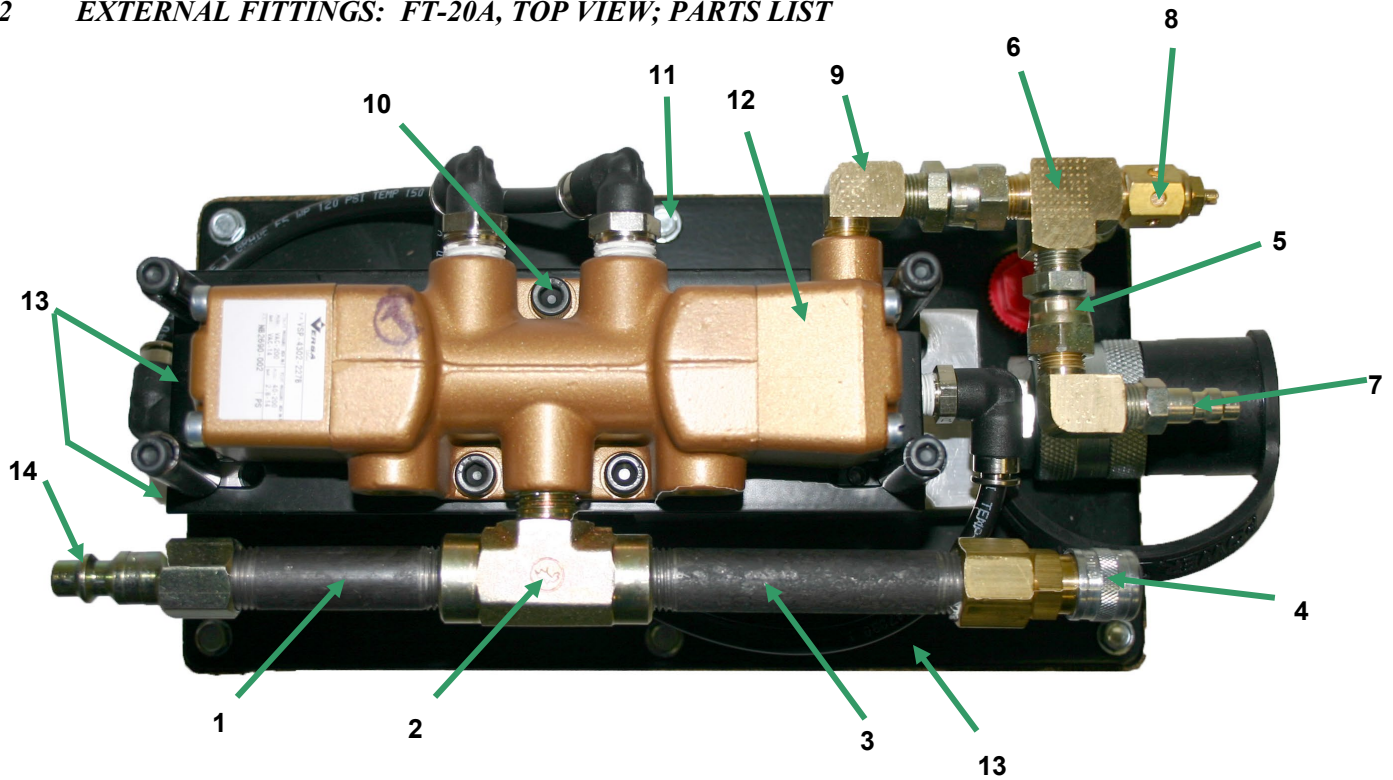

Item Number	FTI Part Number	SPX Part Number	Number Required	Description
1	1125-010	250026	1	1/4-Inch Straight Nipple Fitting
2	1125-012	208699	1	1/4-Inch Tee Fitting
3	1125-039	15426	1	1/4-Inch Straight Nipple Fitting
4	1125-021	250024	1	Quick Coupler (Air Outlet to Puller Unit)
5	1125-013	208218	1	1/8-Inch Straight Fitting
6	1125-014	19463	1	1/8-Inch Tee Fitting
7	1125-020	213343	1	Quick Plug Coupler (Air Inlet from Puller Unit)
8	1125-022	213346	1	Speed Control Muffler (Trigger Response Valve)
9	1125-016	14680	1	90-Degree Elbow Fitting
10	1125-040	10807	3	Hex Socket Head Cap Screw
11	1125-018	211060	6	Plastic Screw (Torque to 25/30 in-lbs)
12	1125-041	351086	1	4-Way Air Valve
13	1125-042	351096-BK2	1	Valve Mounting Plate
14	1125-019	250025	1	Quick Coupler (Main Air Intake)

Figure 6.2-1
FT-20A External Fittings; Top View

6.3 BASIC PUMP ASSEMBLY: FT-20A, FRONT VIEW; PARTS LIST

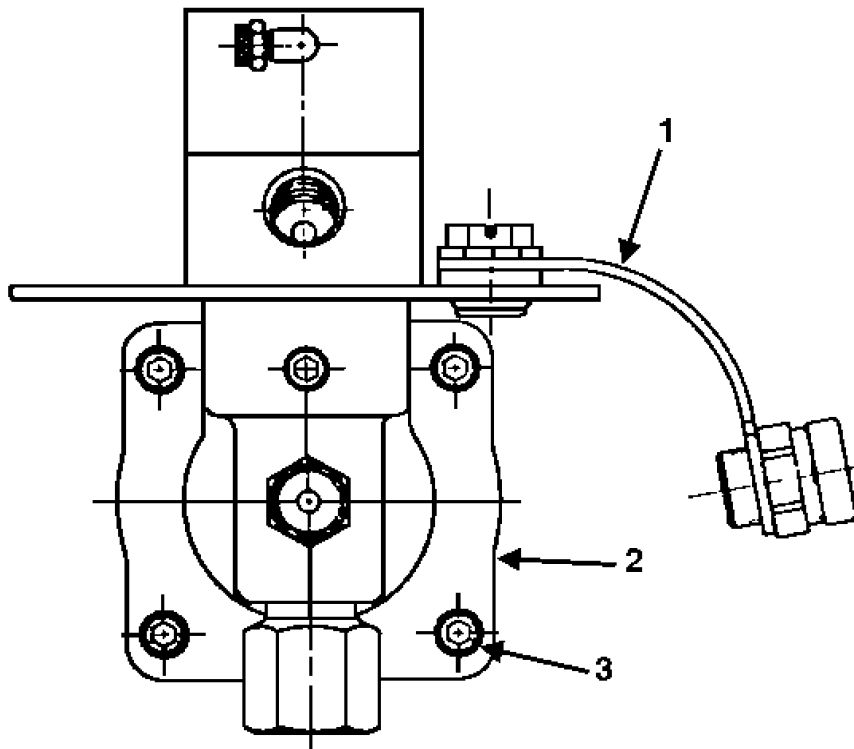

Item Number	FTI Part Number	SPX Part Number	Number Required	Description
1	1125-024	209375	1	Cap and Gasket Assembly (red plug and black operations plug without dipstick [units prior to compliance with European Union Machinery Directive 2006/42/EC])
1	1125-064		1	Aluminum cap with dipstick (units compliant with European Union Machinery Directive 2006/42/EC)
2	1125-043	64767	1	Pump Body
3	1125-025	17428	4	Cos. Head Cap Screw (Torque to 85/95 in-lbs)

Figure 6.3-1
FT-20A Basic Pump Assembly; Front View

FT-20A

6.4 BASIC PUMP ASSEMBLY: FT-20A, TOP VIEW; PARTS LIST

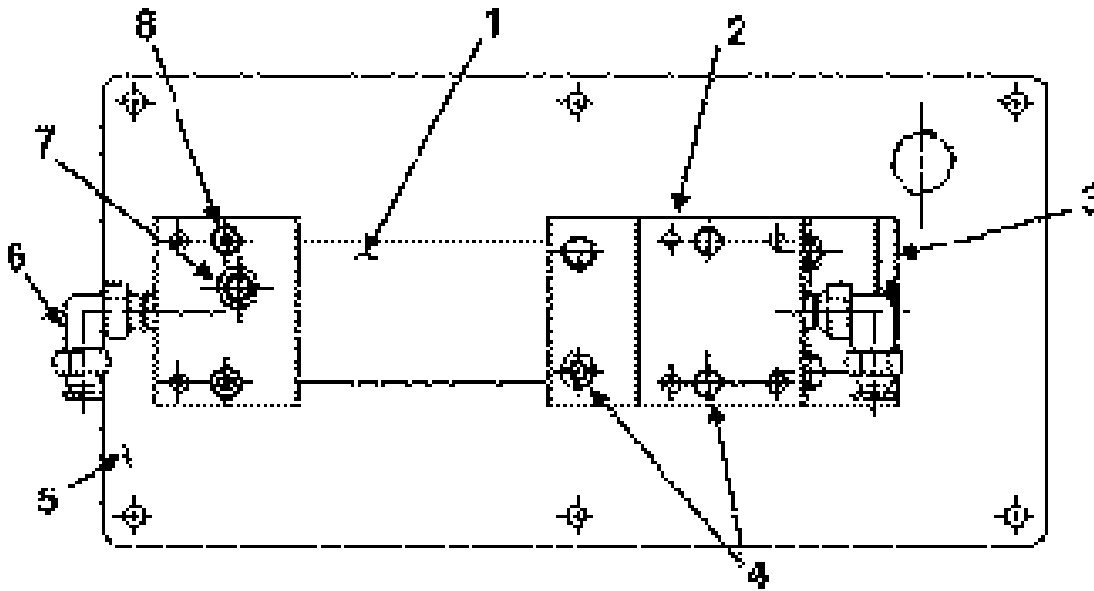

Item Number	FTI Part Number	SPX Part Number	Number Required	Description
1	1125-030	29992	1	Foam Tube
2	1125-048	420293	1	Piston Release Valve Body
3	1125-045	58682	1	Release Valve Body
4	1125-034	11151	4	Socket Head Cap Screw (Torque to 50/60 in-lbs)
5	1125-046	420965-BK2	1	Cover Plate
6	1125-047	250463	2	90-Degree Elbow Fitting
7	1125-031	15499	3	Pipe Plug
8	1125-035	14423	2	Socket Head Cap Screw

Figure 6.4-1
FT-20A Basic Pump Assembly; Top View

SECTION 7.0: FT-20 ILLUSTRATED PARTS BREAKDOWN

Note: There are three configurations of the FT-20 PowerPak: the original FT-20, the revised FT-20A, and the reduced pressure FT-20-4K. The style of pump is identified on Decal #2 in the figure below. Section 6.0 describes the FT-20A, while Section 7.0 describes the original FT-20. Use the FT-20A section for the FT-20-4K.

7.1 EXTERNAL FITTINGS: FT-20 SIDE VIEW; PARTS LIST

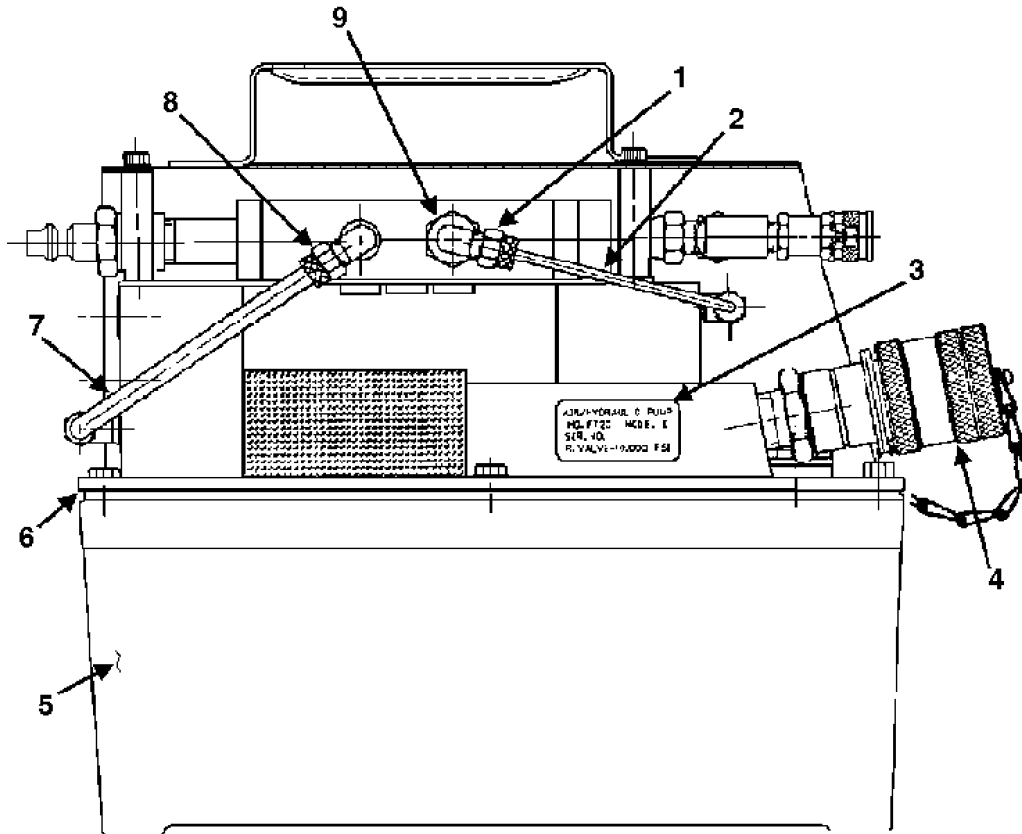

Item Number	FTI Part Number	SPX Part Number	Number Required	Description
1	1125-001	15044	1	90-Degree Elbow Fitting
2	1125-009	14281	0.4 foot	Tubing
3	1125-004	46269	1	Decal
4	1047-013		1	Quick Socket Coupler
5	1125-005	61243	1	Plastic Reservoir
6	1125-007	33853	1	Reservoir Gasket
7	1125-003	14726	0.5 foot	Air Hose
8	1125-002	15457	1	90-Degree Elbow Fitting
9	1125-008	206324	1	Straight Fitting

Figure 7.1-1
FT-20 External Fittings; Side View

FT-20

7.2 EXTERNAL FITTINGS: FT-20 TOP VIEW; PARTS LIST

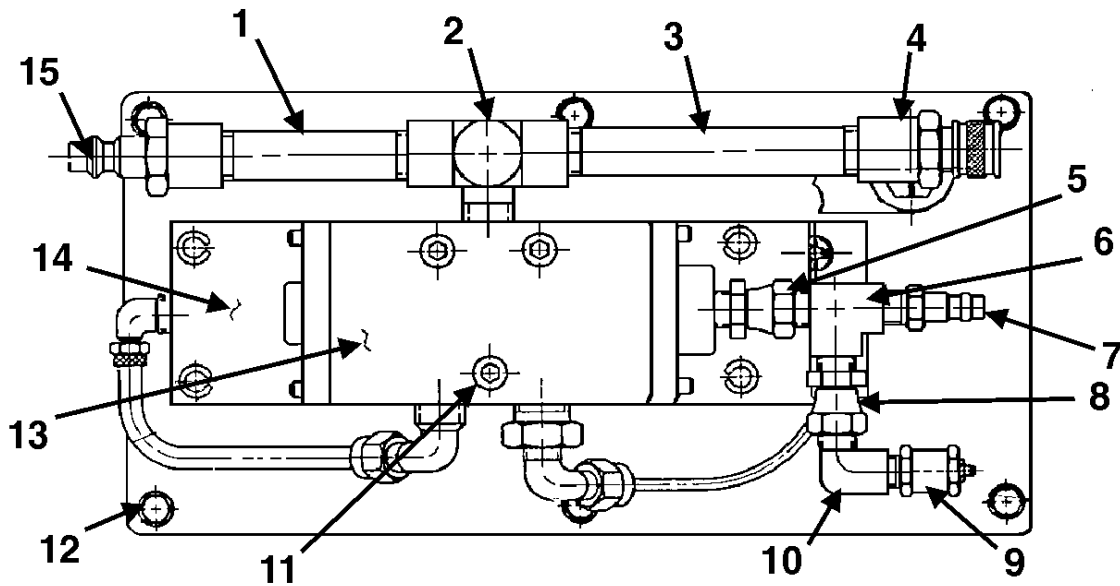

Item Number	FTI Part Number	SPX Part Number	Number Required	Description
1	1125-010	250026	1	1/4-Inch Straight Nipple Fitting
2	1125-012	208699	1	1/4-Inch Tee Fitting
3	1125-011	250027	1	1/4-Inch Straight Nipple Fitting
4	1125-021	250024	1	Quick Coupler (Air Outlet to Tool)
5	1125-013	208218	2	1/8-Inch Straight Fitting
6	1125-014	19463	1	1/8-Inch Tee Fitting
7	1125-020	213343	1	Quick Plug Coupler (Air Inlet from Tool)
8	1125-013	208218	1	1/8-Inch Straight Fitting
9	1125-022	213346	1	Speed Control Muffler
10	1125-016	14680	1	90-Degree Elbow Fitting
11	1125-017	10020	3	Hex Socket Head Cap Screw
12	1125-018	211060	6	Plastic Screw (Torque to 25/30 in-lbs)
13	1125-015	306033	1	4-Way Air Valve
14	1125-023	308406-BK2	1	Valve Mounting Plate
15	1125-019	250025	1	Quick Coupler (Main Air Intake)

Figure 7.2-1
FT-20 External Fittings; Top View

7.3 BASIC PUMP ASSEMBLY: FT-20 FRONT VIEW; PARTS LIST

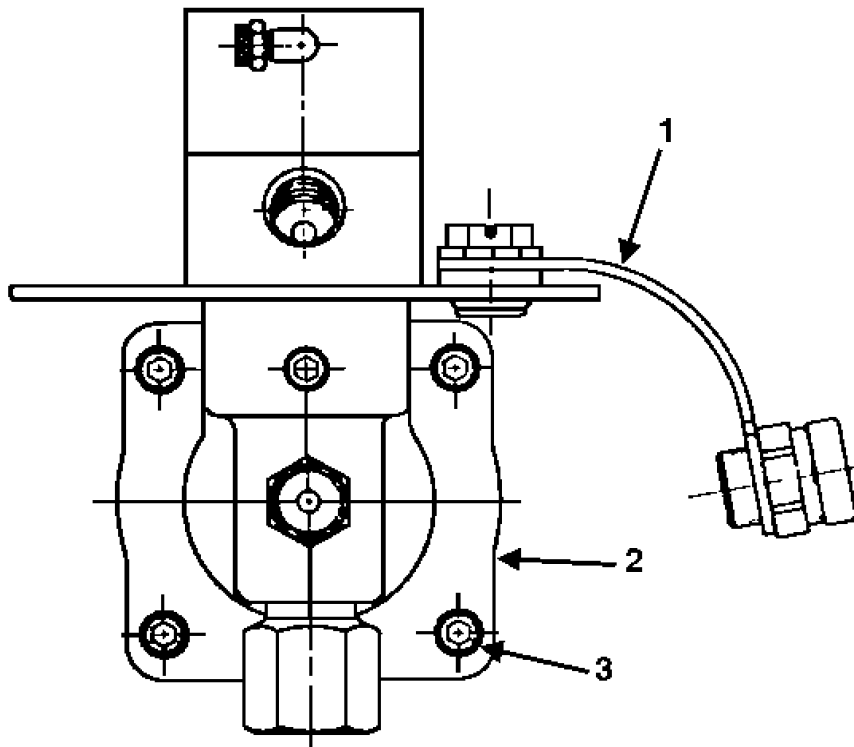

Item Number	FTI Part Number	SPX Part Number	Number Required	Description
1	1125-024	209375	1	Cap and Gasket Assembly (red plug and black operations plug without dipstick [units prior to compliance with European Union Machinery Directive 2006/42/EC])
1	1125-064		1	Aluminum cap with dipstick (units compliant with European Union Machinery Directive 2006/42/EC)
2	1125-026	50494	1	Pump Body
3	1125-025	17428	4	Cos. Head Cap Screw (Torque to 85/95 in-lbs)

Figure 7.3-1
FT-20 Basic Pump Assembly; Front View

7.4 BASIC PUMP ASSEMBLY: FT-20 TOP VIEW; PARTS LIST

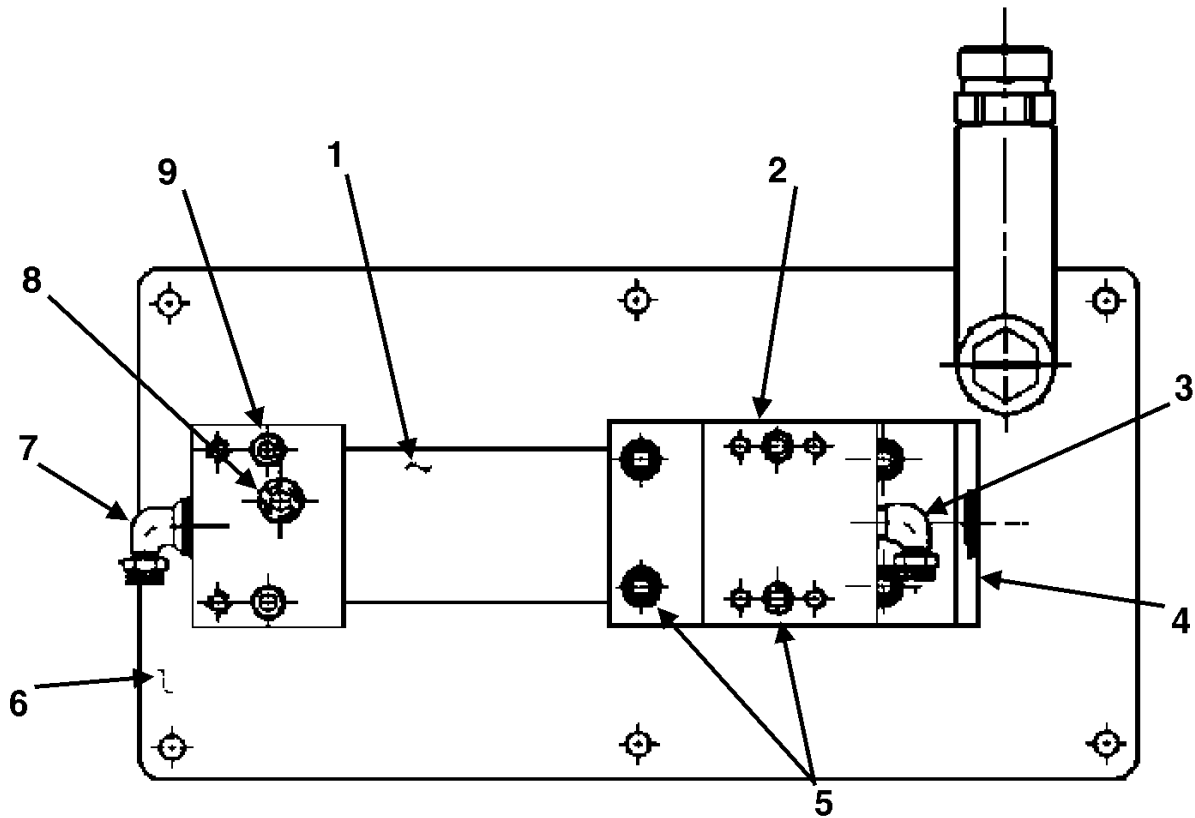

Item Number	FTI Part Number	SPX Part Number	Number Required	Description
1	1125-030	29992	1	Foam Tube
2	1125-032	34759	1	Piston Release Valve Body
3	1125-028	14280	1	90-Degree Fitting
4	1125-033	41598	1	Release Valve Body
5	1125-034	11151	6	Socket Head Cap Screw (Torque to 50/60 in-lbs)
6	1125-029	45840-BK2	1	Cover Plate
7	1125-027	15045	1	90-Degree Elbow Fitting
8	1125-031	15499	3	Pipe Plug
9	1125-035	14423	2	Socket Head Cap Screw

Figure 7.4-1
FT-20 Basic Pump Assembly; Top View

SECTION 8.0: SAFETY DATA SHEET

Safety Data Sheet

In Compliance with Regulation (EC) No. 1272/2008 as amended by
Commission Regulation (EU) 2015/830.

Revision date: 1-2-19

Date of issue: Dec. 27, 2018

Product name: AW Hydraulic Oil ISO 46
--

SECTION 1: Identification of Substance/Product and of the Company/Undertaking
--

1.1 Product identifier

Trade Name:	AW Hydraulic Oil ISO 46
Other names:	Standard Hydraulic Oil
Reach Registration #:	Not Applicable - Mixture
EC Number:	Not Applicable - Mixture
Index Number:	Not Applicable - Mixture
Product Code Number:	9616, 9636, 9637, 9638.
SDS number:	CGF001-EU

1.2 Relevant identified uses of the substance or mixture and uses advised against

Relevant identified uses:	Standard Hydraulic Oil.
Uses advised against:	None known.

1.3 Details of the supplier of the safety data sheet

Supplied By:	
Company Name:	SPXFlow
Company Address:	5885 11th Street Rockford, IL 61109
Company Telephone:	Office hours (Mon – Fri) 8:00am – 5:00pm (CST) (815) 874-5556
Company Contact Name:	EH&S Department.
E-mail address of person Responsible for this SDS:	Info@powerteam.com

1.4 Emergency telephone number

Emergency telephone number (including hours of operation):	INFOTRAC 24 Hour Emergency Numbers: USA, Canada, Puerto Rico (800) 535-5053. International (352) 323-3500.
---	--

Revision Date: January 2, 2019

Page 1 of 11

SAFETY DATA SHEET

AW Hydraulic Oil ISO 46
SDS#: CGF001-EU

SECTION 2: Hazard(s) identification

2.1 Classification of the substance or mixture

Classification in accordance to Regulation (EC) No. 1272/2008 (CLP/GHS).

This product is not hazardous according to the criteria for classification criteria for classification in accordance with Regulation (EC) No 1272/2008.

2.2 Label elements

Labelling in accordance with Regulation 1272/2008 (CLP).

Hazard pictograms: None

Signal word: None

Hazard statements: Not Applicable

Precautionary Statements:

Storage Statements: Not Applicable

Disposal Statements: Not Applicable

Supplemental Hazard Statements: None known

2.3 Other hazards

This substance/mixture contains no components considered to be either persistent, bioaccumulative and toxic (PBT), or very persistent and very bioaccumulative (vPvB) at levels of 0.1% or higher.

SECTION 3: Composition/information on ingredients

3.1 Substance

Not applicable.

3.2 Mixture

Highly refined mineral oils and non-hazardous additives. Contains less than 3% (w/w) DMSO extract for total polycyclic aromatic compound (PAC) using IP 346.

SAFETY DATA SHEET

AW Hydraulic Oil ISO 46
SDS#: CGF001-EU

Product/ Ingredient name	Identifiers	Wt. %	Harmonized Classification Annex VI of (EC) No 1272/2008 CLP	Notes
Distillates (petroleum), solvent- dewaxed heavy paraffinic	CAS No: 64742-65-0 EC No:265-169-7 Index No: 649-474-00-6	50 - 100	Carcinogen – Category 1B:H350	L*
Note L: The Classification as a carcinogen need not apply if it can be shown that the substance contains less than 3% DMSO extract as measured by IP 346 “Determination of polycyclic aromatics in unused lubricating base oils and asphaltene free petroleum fractions – Dimethyl sulphoxide extraction refractive index method”, Institute of Petroleum, London.				

There are no additional ingredients present which, within the current knowledge of the supplier and in the concentrations applicable, are classified as hazardous to health or the environment and hence require reporting in this section. Occupational exposure limits, if available, are listed in section 8. See section 16 for the full text of the H and EUH phrases declared above.

SECTION 4: First-aid Measures

4.1 Description of first aid measures

If inhaled: Move to fresh air. Treat symptomatically. See Section 8 for additional measures to reduce or eliminate exposure. If symptoms persist, seek medical attention.

In case of skin contact: Wash area of contact thoroughly with soap and water. If symptoms persist, seek medical attention.

In case of eye contact: If eyes become irritated, flush immediately with copious amounts of lukewarm water for at least 15 minutes. If easy to do, remove contact lenses. Get medical attention if irritation persists.

If swallowed: DO NOT induce vomiting. Consult a physician if necessary.

4.2 Most important symptoms and effects, both acute and delayed

Not expected to be a health hazard when used under normal conditions. An aspiration hazard may be appropriate if the oil is vaporized under pressure.

4.3 Indication of any immediate medical attention and special treatment needed

No additional information.

SECTION 5: Fire-fighting measures

5.1 Extinguishing media

Suitable extinguishing media: Water spray, Carbon dioxide, Dry chemical, Alcohol foam

Unsuitable extinguishing media: Do not use water jet.

SAFETY DATA SHEET

AW Hydraulic Oil ISO 46
SDS#: CGF001-EU

5.2 Special hazards arising from the substance or mixture

Hazardous combustion products may include carbon monoxide and other toxic gases/vapors.

Hazardous combustion products: Toxic/Irritating fumes, gases and vapours including carbon oxides and other products of incomplete combustion

5.3 Advice for firefighters

Self-contained breathing apparatus and full protective clothing must be worn in case of fire. Fight fire from a protected location. Water may be ineffective in fighting the fire. Use water spray to keep fire-exposed container cool.

SECTION 6: Accidental release measures

6.1 Personal precautions, protective equipment and emergency procedures

For non-emergency personnel

No action shall be taken involving any personal risk or without suitable training. Stop leak if able to do so without risk. Keep unnecessary and unprotected personnel from entering. Eliminated ignition sources. Avoid breathing mist/vapor/aerosol/gas/fume. Do not walk through spilled material. Avoid contact with eyes, skin and clothing. Wear recommended personal protective equipment (refer to Section 8 Exposure controls/ personal protection).

For emergency responders

Keep unauthorized people away and upwind. Wear appropriate personal protective equipment (refer to Section 8 Exposure controls/ personal protection) and avoid inhalation or contact with eyes and skin. See also the information in "For non-emergency personnel".

6.2 Environmental precautions

Prevent further leakage or spillage if safe to do so. Do not let product enter drains waterways or sewer systems. Avoid release to the environment.

6.3 Methods and materials for containment and cleaning up

Absorb in vermiculite, dry sand or earth. Sweep up and place in a clearly labeled container for chemical waste.

6.4 Reference to other sections

See Section 8 for personal protective equipment.

See Section 8 for information on personal protection equipment.

SAFETY DATA SHEET

AW Hydraulic Oil ISO 46
SDS#: CGF001-EU

SECTION 7: Handling and Storage

7.1 Precautions for safe handling

Avoid breathing mist or vapors. Avoid contact with eyes. Use only with adequate ventilation. Wash thoroughly after handling. Observe good personal hygiene practices. Change protective gloves/clothing when signs of contamination appear. Keep out of reach of children.

7.2 Conditions for safe storage, including any incompatibilities

Store in original factory container in a dry area. Do not transfer to an unmarked container. Keep container tightly closed and in a well-ventilated place. Store away from heat and light. Refer to Section 10 – Stability and Reactivity for incompatibilities.

7.3 Specific end use(s):

Apart from the uses mentioned in section 1.2 no other specific uses are stipulated.

SECTION 8: Exposure controls/personal protection

8.1 Control parameters

Occupational exposure limit values:

Ingredient name	Occupational exposure limits	Source
Oil Mist, Mineral	TWA: 5 mg/m ³ (8 hr.)	USA: OSHA PEL
	TWA: 5 mg/m ³ (8 hr.)	USA: ACGIH TLV
	TWA: 5 mg/m ³ (8 hr.)	USA: NIOSH REL
	STEL: 10 mg/m ³ (15 min.)	USA: NIOSH REL
	TWA: 5 mg/m ³ (8 hr.)	Austria: MAK
	TWA: 1 mg/m ³ (8 hr.)	Denmark: Limit Values
	STEL: 2 mg/m ³ (15 min.)	Denmark: Limit Values
TWA: 5 mg/m ³ (8 hr.)	Netherlands: MAC OELs	

Monitoring procedures: Use methods described in European Standards.

8.2 Exposure controls

Appropriate Engineering Measures

Maintain air concentrations below occupational exposure standards using engineering controls if necessary. Local exhaust ventilation is recommended. Eye wash station and showers required for emergency use.

Individual protection measures, such as personal protective equipment:

Eye and face protection: Wear safety glasses or full-face shield if splashes are likely to occur. If possible, have eye-washing facilities readily available where eye irritation can occur. Use equipment for eye protection tested and approved under appropriate government standards such as EN 166(EU).

SAFETY DATA SHEET

AW Hydraulic Oil ISO 46
SDS#: CGF001-EU

Skin protection:

Hand protection: Where hand contact with the product may occur the use of gloves approved to relevant standards made from the following materials may provide suitable chemical protection: PVC, neoprene or nitrile rubber gloves. The selected protective gloves have to satisfy the specifications of EU Directive 89/686/EEC and the standard EN 374 derived from it. Suitability and durability of a glove is dependent on usage, e.g. frequency and duration of contact, chemical resistance of glove material, glove thickness, dexterity. Always seek advice from glove suppliers. Contaminated gloves should be replaced. Personal hygiene is a key element of effective hand care. Gloves must only be worn on clean hands. After using gloves, hands should be washed and dried thoroughly. Application of a non-perfumed moisturizer is recommended.

Other skin protection: Use as necessary to prevent exposure. Work clothing should be changed daily. Contaminated clothing should be removed and washed thoroughly before re-using.

Respiratory protection: No respiratory protection is ordinarily required under normal conditions of use. In accordance with good industrial hygiene practices, precautions should be taken to avoid breathing of material. If engineering controls do not maintain airborne concentrations to a level which is adequate to protect worker health, select respiratory protection equipment suitable for the specific conditions of use and meeting relevant legislation. Check with respiratory protective equipment suppliers. Where air-filtering respirators are suitable, select an appropriate combination of mask and filter. Use respirators and components tested and approved under appropriate government standards such as CEN (EU).

Thermal hazards: None known

Environmental exposure controls

Prevent further leakage or spillage if safe to do so. Do not let product enter drains. Discharge into the environment must be avoided.

SECTION 9: Physical and chemical properties

9.1 Information on basic physical and chemical properties

Appearance	
Physical state:	Liquid
Form:	Liquid
Color:	Blue
Odor:	Mild
Odor threshold:	Not available
pH:	Not available
Melting point/freezing point:	Not available
Initial boiling point and boiling range:	Not available
Flash point:	>380 °F
Evaporation rate:	Not available
Flammability (solid, gas):	Not available

Revision Date: January 2, 2019

Page 6 of 11

SAFETY DATA SHEET

AW Hydraulic Oil ISO 46
SDS#: CGF001-EU

Upper/lower flammability or explosive limits

Flammability limit – lower (%):	Not available
Flammability limit – upper (%):	Not available
Explosive limit – lower (%):	Not available
Explosive limit – upper (%):	Not available
Vapor pressure:	Not available
Vapor density:	Not available
Relative density:	0.87 -0.89
Solubility(ies):	Insoluble
Partition coefficient (n-octanol/water):	Not available.
Auto-ignition temperature:	Not available
Decomposition temperature:	Not available
Viscosity:	46 cSt @40 degrees C
Explosive properties:	Not available
Oxidizing properties:	Not available

9.2 Other information:

No further data available

SECTION 10: Stability and Reactivity

10.1 Reactivity

No hazardous reactions anticipated under normal storage and handling conditions.

10.2 Chemical stability

Stable under normal storage and handling conditions.

10.3 Possibility of hazardous reactions

No hazardous reactions anticipated under normal storage and handling conditions.

10.4 Conditions to avoid

Incompatible materials, Extreme heat, Open Flame, Sparks

10.5 Incompatible materials

Oxidizing Agents

10.6 Hazardous decomposition Products

Not anticipated under normal conditions of use.

SECTION 11: Toxicological information

11.1 Information on toxicological effects

Routes of Exposure: Oral, Dermal, Inhalation, Eye Contact

SAFETY DATA SHEET

AW Hydraulic Oil ISO 46
SDS#: CGF001-EU

Numerical measures of toxicity

Acute Toxicity Data:

Substance	Test Type (species)	Value
Distillates (petroleum), solvent- dewaxed heavy paraffinic	LD ₅₀ Oral (Rat)	>5000 mg/kg
	LD ₅₀ Dermal (Rabbit)	>5000 mg/kg
	LC ₅₀ Inhalation (Rat)	>5 mg/l (4h)

Acute Toxicity:	Does not meet the criteria for classification as Acutely Toxic by inhalation, ingestion or skin contact.
Skin corrosion/irritation:	Does not meet the criteria for classification.
Serious eye damage/eye irritation:	Does not meet the criteria for classification.
Respiratory sensitization:	Does not meet the criteria for classification.
Skin sensitization:	Does not meet the criteria for classification.
Germ cell mutagenicity:	Does not meet the criteria for classification.
Carcinogenicity:	Does not meet the criteria for classification.
Reproductive toxicity:	Does not meet the criteria for classification.
STOT - Single exposure:	Does not meet the criteria for classification.
STOT - Repeat exposure:	Does not meet the criteria for classification.
Aspiration hazard:	Does not meet the criteria for classification.

SECTION 12: Ecological information

12.1 Toxicity

Ingredient Information:

Ingredient	Test Type	Species	Value
Distillates (petroleum), solvent- dewaxed heavy paraffinic	LL/EL/IL50 NOEC/NOEL	Fish	Practically nontoxic: LL/EL/IL50 > 100 mg/l NOEC/NOEL > 100 mg/l (based on test data)
	LL/EL/IL50 NOEC/NOEL	Invertebrate	Practically nontoxic: LL/EL/IL50 > 100 mg/l NOEC/NOEL expected to be > 1.0 - <= 10 mg/l (based on test data)
	LL/EL/IL50	Algae	Practically nontoxic: LL/EL/IL50 > 100 mg/l

Revision Date: January 2, 2019

Page 8 of 11

SAFETY DATA SHEET

AW Hydraulic Oil ISO 46
SDS#: CGF001-EU

12.2 Persistence and Degradability:

Major constituents are expected to be readily biodegradable, but the product contains components that may persist in the environment.

12.3 Bioaccumulative potential:

Contains components with the potential to bioaccumulate.

12.4 Mobility in soil:

If it enters soil, it will adsorb to soil particles and will not be mobile.

12.5 Results of PBT and vPvB assessment:

This substance/mixture contains no components considered to be either persistent, bioaccumulative and toxic (PBT), or very persistent and very bioaccumulative (vPvB) at levels of 0.1% or higher.

12.6 Other adverse effects:

None Known

12.7 Additional information:

None known

SECTION 13: Disposal considerations

13.1 Waste treatment methods

Product

Dispose of in accordance with all applicable local, state, national and international regulations. Recover or recycle if possible. It is the responsibility of the waste generator to determine the toxicity and physical properties of the material generated to determine the proper waste classification and disposal methods. Do not dispose into the environment, in drains or in water courses.

Contaminated packaging

Contaminated packaging may contain traces of the product and therefore should be disposed of in the same way as product.

SECTION 14: Transport Information

International transport regulations

14.1 UN number

ADR/RID: Not Applicable

IMDG: Not Applicable

IATA: Not Applicable

SAFETY DATA SHEET

AW Hydraulic Oil ISO 46
SDS#: CGF001-EU

14.2 Proper shipping name

ADR/RID: Not Regulated for Transport.

IMDG: Not Regulated for Transport.

IATA: Not Regulated for Transport.

14.3 Transport hazard class(es)

ADR/RID: Not Applicable

IMDG: Not Applicable

IATA: Not Applicable

14.4 Packing group

ADR/RID: III

IMDG: III

IATA: III

14.5 Environmental hazard

Marine Pollutant: No

14.6 Special precautions for user

No additional information.

14.7 Transport to bulk according to Annex II of MARPOL and the IBC Code

No additional information.

SECTION 15: Regulatory Information

15.1 Safety, health and environmental regulations/legislation specific for the substance or mixture

This safety datasheet complies with the requirements of:
EU Commission Regulation (EU) 2015/830 (Reach)
EU Regulation (EC) No 1272/2008 (CLP)

EINECS: All components in this product are listed on the European Inventory of Existing Chemical Substance

15.2 Chemical safety assessment

A chemical safety assessment has not been carried out.

SECTION 16: Other Information

Full text of H Codes referred to in section 3.

H350 May cause cancer.

Training advice: Before using/handling the product one must read carefully present SDS.

SAFETY DATA SHEET

AW Hydraulic Oil ISO 46
SDS#: CGF001-EU

Abbreviations and acronyms:

ACGIH:	American Conference of Governmental Industrial Hygienists
ADR:	Accord européen sur le transport des marchandises dangereuses par Route European Agreement concerning the International Carriage of Dangerous Goods by Road
CAS:	Chemical Abstracts Service (division of the American Chemical Society)
CLP:	Classification, Labelling and Packaging
OSHA:	Occupational Safety and Health Administration
EINECS:	European Inventory of Existing Commercial Chemical Substances
EC50:	Half maximal effective concentration
EU:	European Union
GHS:	Globally Harmonized System of Classification and Labeling of Chemicals
IATA:	International Air Transport Association
IBC CODE:	Intermediate Bulk Container
IMDG:	International Maritime Code for Dangerous Goods
LC50:	Lethal concentration, 50 percent
LD50:	Lethal dose, 50 percent
NIOSH:	National Institute for Occupational Safety & Health
OEL:	Occupational Exposure Limits
PEL:	Permissible Exposure Limits
REACH:	Registration, Evaluation and Authorization of Chemicals
REL:	Recommended Exposure Limits
RID:	Gefahrgutvorschriften für den Transport mit der Eisenbahn
STEL:	Short Term Exposure Limits
TLV:	Threshold Limit Value
TWA:	Time Weighted Average
STEL:	Short Term Exposure Limits
UN:	United Nations

Document history

Date of issue:	December 27, 2018
Supersedes:	New document
Reason for revision:	Created to comply with EU requirements

DISCLAIMER:

To the best of our knowledge, the information contained herein is accurate. However SPXFlow does not assume any liability whatsoever for the accuracy or completeness of the information contained herein. Final determination of suitability of any material is the sole responsibility of the user. All materials may present unknown hazards and should be used with caution. Although certain hazards are described herein, we cannot guarantee that these are the only hazards which exist.

MATERIAL SAFETY DATA SHEET

NAME OF PRODUCT: AW Hydraulic Oil ISO 46

FILE NO. 9636, 9637, 9638, 9616, 11360

MSDS DATE: December, 2009

SECTION 1: PRODUCT AND COMPANY IDENTIFICATION

PRODUCT NAME: AW Hydraulic Oil ISO 46
SYNONYMS: hydraulic fluid
PRODUCT CODES: 9616,9636,9637,9637Tray,9638,11360, CG46AWBlue

MANUFACTURER: CGF INC
DIVISION: N/A
ADDRESS: 317 Peoples Avenue Rockford, IL 61104 USA

EMERGENCY PHONE: 800/424-9300
CHEMTREC PHONE: 800/424-9300
OTHER CALLS: 815-967-4400
FAX PHONE: 815-967-4404

PRODUCT USE: Hydraulic Fluid
PREPARED BY: Irena Larson/Denise Brauer

SECTION 1 NOTES:

SECTION 2: COMPOSITION/INFORMATION ON INGREDIENTS

INGREDIENT: Petroleum base oils, additive package.

<u>CAS NO.</u>	<u>% WT</u>	<u>% VOL</u>	<u>SARA 313 REPORTABLE</u>
64741-88-4	75-85		None
64742-01-4	15-25		None
Proprietary Additive(s)	0.5-1.5		None

SECTION 3: HAZARDS IDENTIFICATION

EMERGENCY OVERVIEW: This material is not considered hazardous according to OSHA criteria.

ROUTES OF ENTRY: Skin contact or inhalation.

POTENTIAL HEALTH EFFECTS

EYES: Contact may cause mild eye irritation including stinging, watering, and redness.

SKIN: Contact may cause mild skin irritation including redness and a burning sensation. Prolonged or repeated contact can defat the skin, causing drying and cracking of the skin and possibly dermatitis (inflammation). No harmful effects from skin absorption are expected.

INGESTION: No harmful effects expected from ingestion.

INHALATION: No information available on acute toxicity.

ACUTE HEALTH HAZARDS: No

CHRONIC HEALTH HAZARDS: No

MEDICAL CONDITIONS GENERALLY AGGRAVATED BY EXPOSURE: Skin disorders may be aggravated by exposure.

CARCINOGENICITY

OSHA: None

ACGIH: None

NTP: None

IARC: None

OTHER:

SECTION 3 NOTES:

MATERIAL SAFETY DATA SHEET

NAME OF PRODUCT: AW Hydraulic Oil ISO 46

FILE NO. 9636, 9637, 9638, 9616, 11360

MSDS DATE: December, 2009

SECTION 4: FIRST AID MEASURES

EYES: If irritation or redness develops, flush eyes with clean water. If symptoms persist, seek medical attention.

SKIN: Remove contaminated shoes and clothing and cleanse affected area(s) thoroughly by washing with a mild soap and water or a waterless hand cleaner. If irritation persists, seek medical attention.

INGESTION: First aid is not normally required; however, if swallowed and symptoms develop, seek medical attention.

INHALATION: If respiratory symptoms develop, move victim away from source of exposure and into fresh air. If symptoms persist, seek medical attention.

NOTES TO PHYSICIANS OR FIRST AID PROVIDERS: High-pressure hydrocarbon injection injuries may produce substantial necrosis of underlying tissue despite an innocuous appearing wound. Often these injuries require emergency surgical debridement and all injuries should be evaluated by a specialist in order to assess the extent of injury.

Acute aspirations of large amounts of mineral oil-laden material may produce serious aspiration pneumonia. Patients who aspirate these oils should be followed for the development of long-term sequelae. Inhalation exposure to oil mists below current workplace exposure limits is unlikely to cause pulmonary abnormalities.

SECTION 4 NOTES:

SECTION 5: FIRE-FIGHTING MEASURES

EXTINGUISHING MEDIA: Dry chemical, carbon dioxide, foam, or water spray is recommended.

SPECIAL FIRE FIGHTING PROCEDURES:

Water or foam may cause frothing of materials heated above 212 F. Carbon dioxide can displace oxygen. Use caution when applying dioxide in confined spaces.

SPECIAL PROTECTIVE EQUIPMENT: For fires in enclosed areas, fire fighters must use self-contained breathing apparatus.

UNUSUAL FIRE AND EXPLOSION HAZARDS: This material may burn, but will not ignite readily. If container is not properly cooled, it can rupture in the heat of fire.

HAZARDOUS DECOMPOSITION PRODUCTS: No data

Flash Point: C(F) : >210(410) (ASTM D-92)

Flammable Limits (approx. % vol. in air)- LEL: 0.9%, UEL: 7.0%

NFPA HAZARD ID: Health: 1, Flammability: 1, Reactivity: 0

SECTION 6: ACCIDENTAL RELEASE MEASURES

ACCIDENTAL RELEASE MEASURES:

Personal Precautions:

This material may burn, but will not ignite readily. Keep all sources of ignition away from spill/release. The use of explosion-proof electrical equipment is recommended. Stay upwind and away from spill/release. Notify persons downwind of the spill/release, isolate immediate hazard area and keep unauthorized personnel out. Wear appropriate protective equipment, including respiratory protection, as conditions warrant.

Environmental Precautions: Stop spill/release if it can be done with minimal risk. Prevent spilled material from entering sewers, storm drains, other unauthorized drainage systems, and natural waterways. Contact appropriate agency for spills into or upon navigable waters that cause a sheen or discoloration on the water surface.

Methods for Containment and Clean Up:

Notify fire authorities and appropriate regulatory authorities. Immediate cleanup of any spill is recommended. Dike far ahead of spill for later recovery or disposal. Spilled material may be absorbed into an appropriate absorbent material.

SECTION 7: HANDLING AND STORAGE

HANDLING AND STORAGE:

Wash thoroughly after handling. Use good personal hygiene practices and wear appropriate personal protective equipment. High pressure injection of hydrocarbon fuels, hydraulic oils or greases under the skin may have serious consequences even though no symptoms or injury may be apparent. This can happen accidentally when using high pressure equipment such as high pressure grease guns, fuel injection

PAGE 2 OF 6

MATERIAL SAFETY DATA SHEET

NAME OF PRODUCT: AW Hydraulic Oil ISO 46

FILE NO. 9636, 9637, 9638, 9616, 11360

MSDS DATE: December, 2009

apparatus or from pinhole leaks in tubing of high pressure hydraulic oil equipment. Do not enter confined spaces such as tanks or pits without following proper entry procedures. Do not wear contaminated clothing or shoes. "Empty" containers retain residue and may be dangerous. Do not pressurize, cut, weld, braze, solder, drill, grind, or expose such containers to heat, flame, sparks, or other sources of ignition. They may explode and cause injury or death. "Empty" drums should be completely drained, properly bunged, and promptly shipped to the supplier or a drum reconditioner. All containers should be disposed of in an environmentally safe manner and in accordance with governmental regulations. Use and store this material in cool, dry, well-ventilated areas away from heat and all sources of ignition. Keep container(s) tightly closed. Store only in approved containers. Keep away from any incompatible material. Protect container(s) against physical damage.

SECTION 8: EXPOSURE CONTROLS/PERSONAL PROTECTION

Componet	ACGIH	OSHA
Lubricant Base Oil-Petroleum	TWA: 5mg/m ³ STEL: 10mg/m ³ As oil mist, if generated	TWA: 5mg/m ³ as Oil mist, if generated

ENGINEERING CONTROLS: If current ventilation practices are not adequate to maintain airborne concentrations below the established exposure limits, additional engineering controls may be required.

RESPIRATORY PROTECTION: Where there is potential for airborne exposure above the exposure limit a NIOSH certified air purifying respirator equipped with R or P95 filters may be used. A respiratory protection program that meets or is equivalent to OSHA 29 CFR 1910.134 and ANSI Z88.2 should be followed whenever workplace conditions warrant a respirator's use. Air purifying respirators provide limited protection and cannot be used in atmospheres that exceed the maximum use concentration (MUC) as directed by regulation or the manufacturer's instructions, in oxygen deficient (less than 19.5 percent oxygen) situations, or other conditions that are immediately dangerous to life and health (IDLH).

EYE PROTECTION: The use of eye protection that meets or exceeds ANSI Z.87.1 is recommended to protect against potential eye contact, irritation, or injury. Depending on conditions of use, a face shield may be necessary.

SKIN PROTECTION: The use of gloves impervious to the specific material handled is advised to prevent skin contact. Users should check with manufacturers to confirm the performance of their products. Suggested protective materials: Nitrile

SECTION 8 NOTES: State, local or other agencies or advisory groups may have established more stringent limits. Consult an industrial hygienist or similar professional, or your local agencies, for further information.

SECTION 9: PHYSICAL AND CHEMICAL PROPERTIES

APPEARANCE: Clear Blue Liquid

ODOR: mild petroleum

PHYSICAL STATE: Liquid

pH AS SUPPLIED: Not applicable

pH (Other):

BOILING POINT: No data

F: >600

C: >316

FLASH POINT:

F: >410

C: >210

METHOD USED: (ASTM D-92)

AUTOIGNITION TEMPERATURE:

F: 671

C: 355

MELTING POINT: No data

F:

C:

FREEZING POINT: No data

F:

PAGE 3 OF 6

MATERIAL SAFETY DATA SHEET

NAME OF PRODUCT: AW Hydraulic Oil ISO 46

FILE NO. 9636, 9637, 9638, 9616, 11360

MSDS DATE: December, 2009

C:

VAPOR PRESSURE (mmHg): <1
@ 20 C : < 0.1

VAPOR DENSITY (AIR = 1): >2
@

F: 68
C: 20

SPECIFIC GRAVITY (H2O = 1): 0.87
@

F: 60
C: 15.6

EVAPORATION RATE: n/a

BASIS (=1):

SOLUBILITY IN WATER: not soluble

PERCENT SOLIDS BY WEIGHT: n/a

PERCENT VOLATILE: Negligible
BY WT/ BY VOL @

F: 68
C: 20

VOLATILE ORGANIC COMPOUNDS (VOC): no data

WITH WATER: LBS/GAL
WITHOUT WATER: LBS/GAL

MOLECULAR WEIGHT: no data

VISCOSITY:
200-300 SUS @ 100 Degree F
@ 40 C cST 47.25

SECTION 9 NOTES: Data represents typical values and are not intended to be specifications.

SECTION 10: STABILITY AND REACTIVITY

STABLE

UNSTABLE

STABILITY: YES

CONDITIONS TO AVOID (STABILITY): Avoid excessive heat, formations of vapors or mists.

INCOMPATIBILITY (MATERIAL TO AVOID): Strong oxidizing agents

HAZARDOUS DECOMPOSITION OR BY-PRODUCTS: None under normal storage.

HAZARDOUS POLYMERIZATION: No

CONDITIONS TO AVOID (POLYMERIZATION): n/a

SECTION 10 NOTES:

SECTION 11: TOXICOLOGICAL INFORMATION

TOXICOLOGICAL INFORMATION:

Carcinogenicity: The petroleum base oils contained in this product have been highly refined by a variety of processes including solvent extraction, hydrotreating, and/or dewaxing to remove aromatics and improve performance characteristics. No components in this formulation have been identified as a carcinogen.

Component
Lubricant Base Oil

Oral LD50
>5g/kg

Dermal LD50
>2g/kg

Inhalation LC50
No data

PAGE 4 OF 6

MATERIAL SAFETY DATA SHEET

NAME OF PRODUCT: AW Hydraulic Oil ISO 46

FILE NO. 9636, 9637, 9638, 9616, 11360

MSDS DATE: December, 2009

SECTION 11 NOTES:

SECTION 12: ECOLOGICAL INFORMATION

ECOLOGICAL INFORMATION: Ecotoxicological data have not been determined specifically for this product. Information given is based on knowledge of the components and the ecotoxicology of similar products.

Acute Toxicity: Poorly soluble mixture. May cause physical fouling of aquatic organisms. Expected to be practically non toxic: LL/EL/IL50 > 100 mg/l (to aquatic organisms) (LL/EL50 expressed as the nominal amount of product required to prepare aqueous test extract). Mineral oil is not expected to cause any chronic effects to aquatic organisms at concentrations less than 1 mg/l.

Mobility: Liquid under most environmental conditions. Floats on water. If it enters soil, it will adsorb to soil particles and will not be mobile.

Persistence/degradability: Expected to be not readily biodegradable. Major constituents are expected to be inherently biodegradable, but the product contains components that may persist in the environment.

Bioaccumulation : Contains components with the potential to bioaccumulate.

Other Adverse Effects: Product is a mixture of non-volatile components, which are not expected to be released to air in any significant quantities. Not expected to have ozone depletion potential, photochemical ozone creation potential or global warming potential

SECTION 12 NOTES:

SECTION 13: DISPOSAL CONSIDERATIONS

WASTE DISPOSAL METHOD:

Material Disposal: Recover or recycle if possible. It is the responsibility of the waste generator to determine the toxicity and physical properties of the material generated to determine the proper waste classification and disposal methods in compliance with applicable regulations. Do not dispose into the environment, in drains or in water courses.

Container Disposal: Dispose in accordance with prevailing regulations, preferably to a recognized collector or contractor. The competence of the collector or contractor should be established beforehand.

Local Legislation: Disposal should be in accordance with applicable regional, national, and local laws and regulations.

SECTION 14: TRANSPORT INFORMATION

U.S. DEPARTMENT OF TRANSPORTATION: Not regulated

PROPER SHIPPING NAME:

HAZARD CLASS:

ID NUMBER:

PACKING GROUP:

LABEL STATEMENT:

WATER TRANSPORTATION: Not regulated

PROPER SHIPPING NAME:

HAZARD CLASS:

ID NUMBER:

PACKING GROUP:

LABEL STATEMENTS:

AIR TRANSPORTATION: Not regulated

PROPER SHIPPING NAME:

HAZARD CLASS:

ID NUMBER:

PACKING GROUP:

LABEL STATEMENTS:

OTHER AGENCIES:

SECTION 14 NOTES:

SECTION 15: REGULATORY INFORMATION

U.S. FEDERAL REGULATIONS

MATERIAL SAFETY DATA SHEET

NAME OF PRODUCT: AW Hydraulic Oil ISO 46

FILE NO. 9636, 9637, 9638, 9616, 11360

MSDS DATE: December, 2009

TSCA (TOXIC SUBSTANCE CONTROL ACT): All components of this formulation are listed on the US EPA-TSCA inventory or not regulated under TSCA.

EU Labeling: Product is not dangerous as defined by the European Union Dangerous Substances/Preparations Directives. EU labeling is not required.

Governmental Inventory Status: All components comply with TSCA, EINECS/ELINCS, AICS, METI, DSL, KOREA, and PHILIPPINES.

CERCLA (COMPREHENSIVE RESPONSE COMPENSATION, AND LIABILITY ACT): This material does not contain any chemicals subject to the reporting requirements of SARA 302 and 40 CFR 372.

SARA TITLE III (SUPERFUND AMENDMENTS AND REAUTHORIZATION ACT): This product contains no "EXTREMELY HAZARDOUS SUBSTANCES".

311/312 HAZARD CATEGORIES: None

Acute Health: No
Chronic Health: No
Fire Hazard: No
Pressure Hazard: No
Reactive Hazard: No

313 REPORTABLE INGREDIENTS: This material does not contain any chemicals subject to the reporting requirements of SARA 313 and 40 CFR 372.

STATE REGULATIONS: This material does not contain any chemicals with CERCLA Reportable Quantities.

California Proposition 65:

This material does not contain any chemicals which are known to the State of California to cause cancer, birth defects or other reproductive harm at concentrations that trigger the warning requirements of California Proposition 65.

INTERNATIONAL REGULATIONS:

Canadian Regulations:

This product has been classified in accordance with the hazard criteria of the Controlled Products Regulations (CPR) and the MSDS contains all the information required by the CPR.

WHMIS Hazard Class

None

SECTION 15 NOTES:

SECTION 16: OTHER INFORMATION

OTHER INFORMATION:

PREPARATION INFORMATION: Issue Date: August 2009 Rev. #1

DISCLAIMER:

The information presented herein has been compiled from sources considered to be dependable and accurate to the best of Cutting & Grinding Fluids Inc., knowledge. However, CGF INC., makes no warranty whatsoever expressed or implied of merchantability or fitness for the particular purpose, regarding the accuracy of such data or the results to be obtained from the use thereof. Cutting & Grinding Fluids, Inc. assumes no responsibility for the injury to recipient or to the third persons or for any damage to any property and recipient assumes all such risks.

This page intentionally left blank.



FATIGUE TECHNOLOGY INC.
401 Andover Park East
Seattle, Washington 98188-7605
USA

E.C. DECLARATION OF CONFORMITY

Manufacturer: Fatigue Technology Inc.
401 Andover Park East
Seattle, WA 98188-7605

Telephone: (206) 246-2010
Fax: (206) 244-9886

Responsible Person in E.C.: KALISTRUT AEROSPACE
COUDRIN, Jerome
1 Av. Marc Seguin
26240 Saint-Vallier
France

Telephone: 33 (0)6-72-28-66-54

The undersigned declares that the machinery described:

Type: _____

Serial Number: _____

Conforms to the following directives:

Council Directive 2006/42/EC (the Machinery Directive)
ISO 11148-1 Hand-Held Non-Electric Power Tools – Safety Requirements – Part 1
ISO 4413 Hydraulic fluid power – General rules and safety requirements for systems and their components
ISO 4414 Pneumatic fluid power – General rules and safety requirements for systems and their components

and complies with the relevant health and safety requirements.

Jeff Sageman
Logistics Manager

Date

This page intentionally left blank.