

TF 974 / 976

Oil burner safety control

For 1- or 2-stage oil burners up to 30 kg/h throughput and intermittent operation with or without oil preheating

Flame detection:

- Photo resistor MZ 770 S
- Infrared-flicker detector IRD 1010
- UV flame sensor UVD 970

INTRODUCTION

The TF 974 or TF 976 oil burner safety control boxes are suitable for oil burners which may be equipped with a oil preheater up to 30 kg/h capacity. The control boxes are approved and certified according to EN 230.

A special contact in the control unit short-circuits the thermo-switch of the fuel heater as soon as the burner is operating and the flame signal is present. Therefore interruption of the burner operation due to decreasing oil temperature can be prevented (e.g. in case of high oil flow).

If the control box goes into lock-out mode, the oil preheater power supply is also disconnected.

TYPES AVAILABLE

TF 974	1-stage operation post-ignition time ca. 20 sec. low voltage protection according to EN 230
TF 976	2-stage operation post-ignition time ca. 2 - 4 sec. low voltage protection according to EN 230

CONSTRUCTIONAL FEATURES

The control box circuitry is protected by a flame resistant, transparent housing. It incorporates the thermomechanical, temperature composated, flame check and reset circuits.

Manual reset from lockout is provided by a push button with an integrated lockout signal lamp. A central fixing screw locks the control box to the wiring base. The wiring base and control box have a positive plug-in arrangement, making it impossible to achieve an incorrect connection between the two parts.

A variety of cable entry points provides the utmost flexibility for electrical wiring.



TECHNICAL DATA

Operating voltage	220 / 240 V (-15... +10%) 50 Hz (40 - 60 Hz)
Fuse rating	10 A fast, 6 A slow
Power consumption	ca. 5 VA
Max. current rating output terminal	term. 2 0.5 A, cos φ 0.4 term. 3 1.5 A, cos φ 0.2 term. 4 4 A, cos φ 0.4 term. 5 0.5 A, cos φ 0.4 term. 6 4 A, cos φ 0.4 term. 8 0.1 A, cos φ 0.4 total 5 A, cos φ 0.4
Pre-purge time	ca. 12 sec.
Pre-ignition time	ca. 12 sec.
Post-ignition time	ca. 20 sec. TF 974 2 - 4 sec. TF 976
Delay time to oil valve V 2	ca. 20 sec. TF 976
Lockout safety time	10 sec.
Reset time from lockout	ca. 60 sec.
Flame detector	
MZ 770 S	for side-on and end-on viewing
Light sensitivity	> 6 Lux
Sensor operating current	min. 30 μ A
IRD 1010	for side-on or end-on viewing
UVD 970	end-on viewing
Weight incl. wiring base	0,25 kg
Mounting position	any
Protection class	IP 40
Recommended ambient operating temperature for control and flame detector approved according to	0° C... +60° C EN 230

UV SOLID STATE SENSOR UVD 970 APPLICATION NOTES

1. Flame control

The following flame detectors can be used for flame control:

- For yellow oil flame: photoresistor MZ 770 S (side-on or end-on viewing).
- For blue or yellow oil flame: infrared-flame detector type IRD 1010 or as an alternative the UV solid state sensor UVD 970.

Generally, the no flamesignal is generated at light levels below 3 Lux with respect to the operating cycle of the control. According to EN 230 stray light safety level has to be established in conjunction with the accompanying burner. Connecting the IRD 1010 or UVD 970, the correct wiring has to be observed.

2. Burner control

The fuel heater of the burner must have a temperature control switch. The closing contact-switch of the preheater has to be connected between terminals 4 and 6. A special contact in the control unit-connects the thermostwitch of the heater as soon as the burner is operating and a photocurrent is generated. Therefore an interruption of the burner operation due to a decrease in oil temperature is prevented (e.g. high oil flow).

According to EN 230 A2.1, the short circuiting of the thermostwitch is allowed only for an oil flow of max. 10 kg/h oil. Burners with a higher throughput have to shut down if the oil temperature gets below the allowed minimum. In such a case the thermostwitch has to be put in the phasecircuit and terminals 4 and 6 are connected with a link.

With burners without fuel heaters terminals 4 and 6 have to be connected with a jumper.

3. Low Voltage Protection

The start up of the burner can only take place if the mains voltage is higher than a limit which is 15% below nominal value. If the voltage drops below 160V, a start-up is prevented or – without allowing to release the fuel – the control box goes into lock out mode.

4. Safety

The design and the control sequence of the TF 974 and TF 976 control boxes comply with the currently applicable Eu-ropean standards and regulations.

5. Mounting and electrical wiring

Wiring base:

- 3 earth terminals with additional terminal for burner earthing
- 3 neutral terminals with internal permanent connection to neutral terminal (terminal 7)
- 2 spare auxiliary terminals
- 2 slide-in plates and 2 easy-knockout holes (PG 11 thread), plus 2 easy-knockout holes in the base bottom facilitate the base wiring.

General:

- Control box and flame detector should not be subjected to excessive vibration.
- The control box can be mounted in any position. The protection class is IP 40.

INSTALLATION INSTRUCTIONS AND MAINTENANCE

1. Important notes

- The controls must be installed by qualified personnel only. The relevant national regulations have to be observed.
- On commissioning the writing has to be carefully check according to the appropriate diagram. Incorrect wiring can damage the unit and endanger the installation.
- The fuse rating has to ensure that the limits specified in Technical Data will not be exceeded. If these precautions are not observed, the effect of a short circuit can cause severe damage to the control and installation.
- For safety reasons a minimum of one control shut-down per 24 hours has to be observed.
- Disconnect the mains before the control box is plugged in or out!
- The control box is a safety device and must not be opened!

2. Function control

For safety reasons the flame detection system should be tested on commissioning the installation as well as after a service or a longer shut-down.

- a) Start-up with covered flame detector:
 - After lock-out safety time
 - > lockout
- b) Start-up with exposed flame detector:
 - After ca. 20 sec. pre-purge:
 - > lockout
- c) Normal start-up; with burner in the "normal" position, cover up the flame detector:
 - New start-up, after end of lock-out safety time
 - > lockout

3. Fault finding

Burner not working:

- faulty electrical wiring
- thermostat circuit open
- oil preheater defective
- mains voltage below 160V

Burner starts, flame not established = lockout:

- stray light on flame detector.
- no ignition or no fuel.
- mains voltage more than -15% below nominal value.

Burner starts, flame established, after safety time = lockout:

- dirty or faulty flame detector
- insufficient light on detector
- sensitivity adjustment too low on IRD

CIRCUIT AND TIMING DIAGRAM TF 974

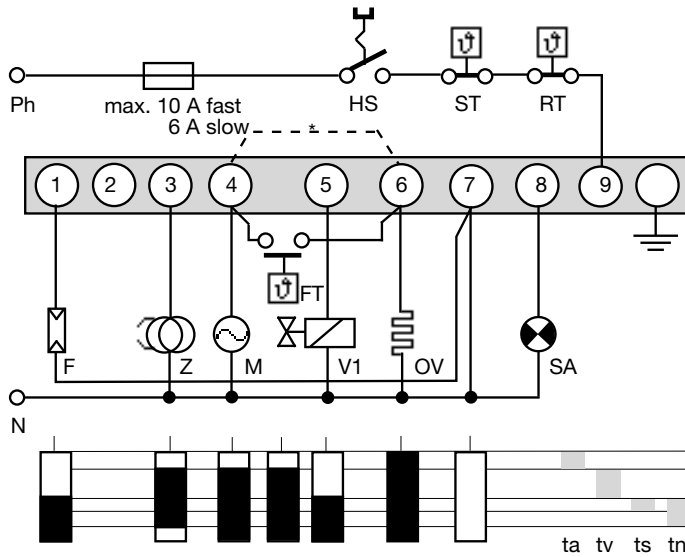

IRD - / UVD-CONNECTION

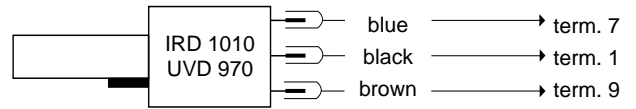

- HS Mains switch
- ST Limit thermostat
- RT Control thermostat
- F Flame detector MZ 770 S (IRD 1010/UVD 970 see separate diagram)
- Z Ignition
- M Burner motor (burner with solenoid valve)
- FT Release thermostat oil preheater
- V Oil solenoid valve
- OV Oil preheater
- SA External lock-out signal.
- * For burners without fuel heaters terminals 4 and 6 have to be connected with a link.
- ta Preheat-time oil preheater
- tv Pre-ignition time with or without pre-purge
- ts Lock-out safety time
- tn Post-ignition time

CIRCUIT AND TIMING DIAGRAM TF 976

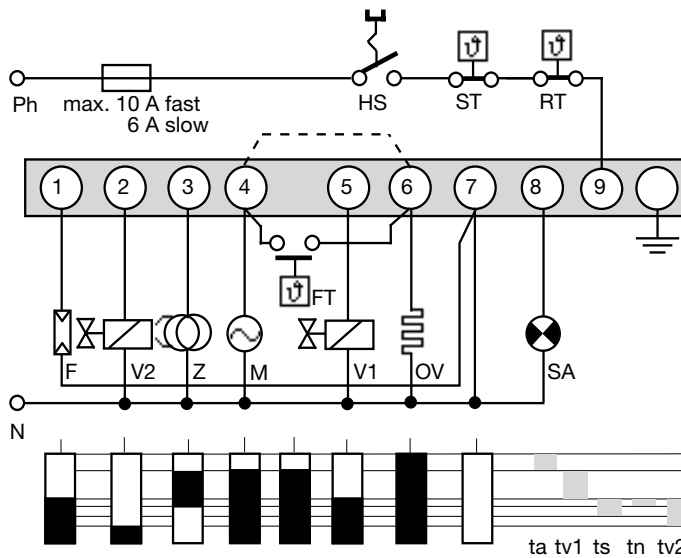

IRD - / UVD CONNECTION

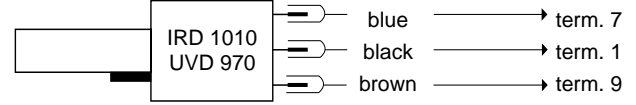

- HS Mains switch
- ST Limit thermostat
- RT Control thermostat
- F Flame detector MZ 770 S (IRD 1010/UVD 970 see separate diagram)
- Z Ignition
- M Burner motor (burner with solenoid valve)
- V1, V2 Oil solenoid valves
- FT Release thermostat oil preheater
- OV Oil preheater
- SA External lock-out signal.
- * For burners without fuel heater terminals 4 and 6 have to be connected with a link
- ta Preheat-time oil preheater
- tv1 Pre-ignition time with or without pre-purge
- ts Lock-out safety time
- tn Post ignition time
- tv2 Delay 2nd stage

SCHEMATIC DIAGRAM TF 974

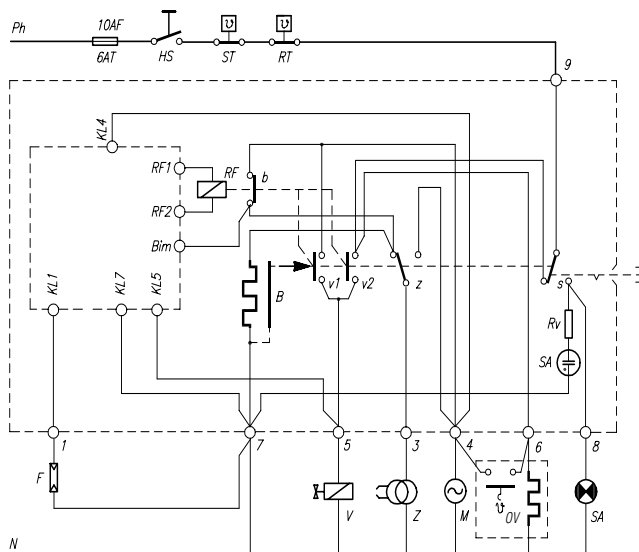

SCHEMATIC DIAGRAM TF 976

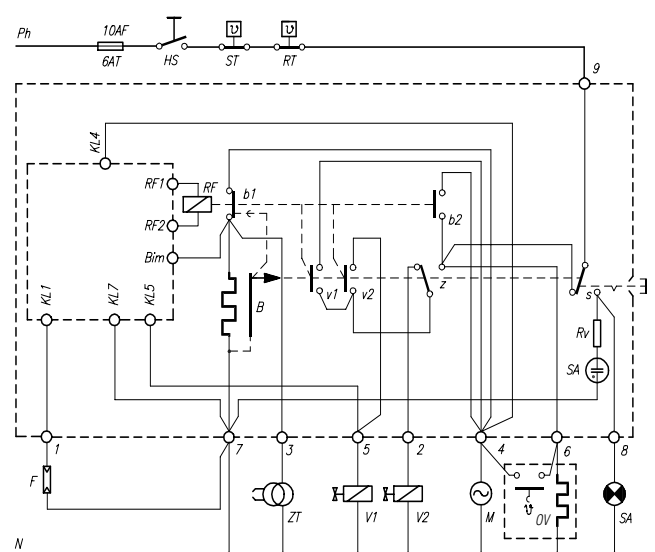

- HS Mains switch
- ST Limit thermostat
- RT Control thermostat
- SA Lock-out signal indicator
- F Flame detector MZ 770 S
- V Valves
- Z Ignition
- M Burner motor
- OV Oil preheater
- RF Flame relay
- B Thermomechanical timer
- RV Resistor

TF 974 / 976 AND SOCKET

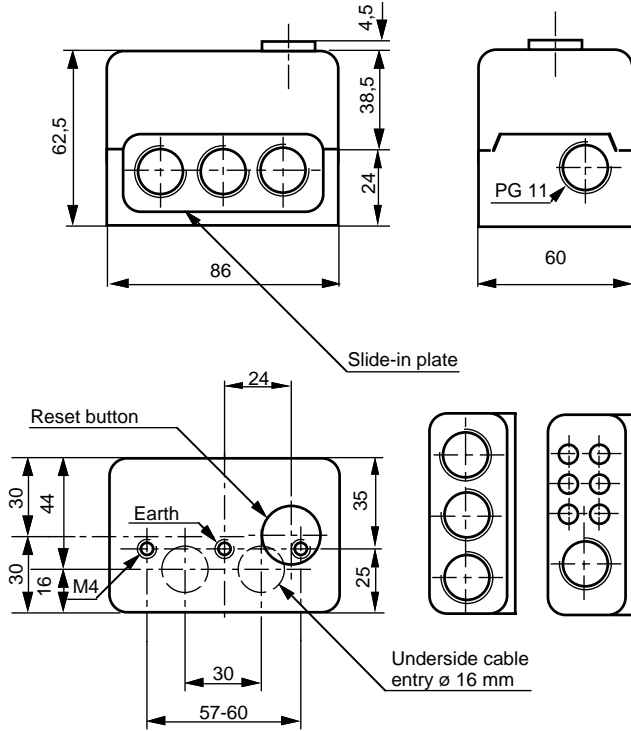

HOLDER FOR MZ 770 S

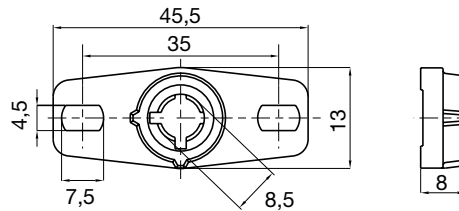

SHAFT MZ 770 S

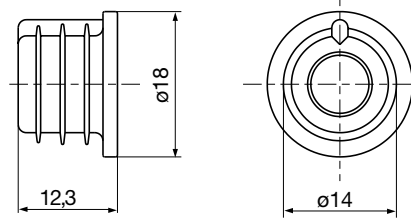

PHOTORESISTOR MZ 770 S

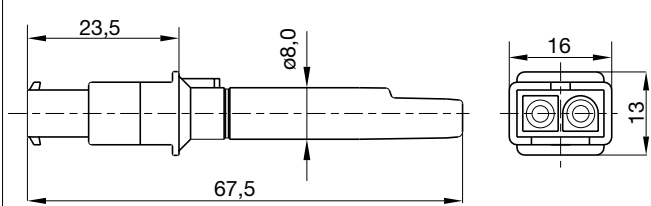

IRD 1010

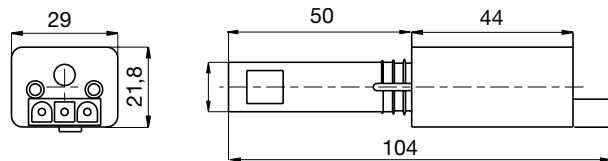

UVD 974

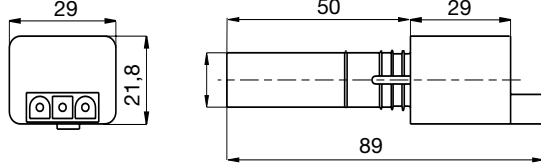

HOLDER M 74 FOR IRD OR UVD

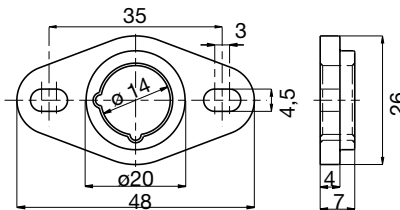

ORDERING INFORMATION

ITEM	DESIGNATION	ITEM NO.
Control box	Typ TF 974	02524
or	Typ TF 976	02526
Socket	Socket 701 ABEN 7	70011
Insert plate	PG-Plate	70502
optional	Cable entry plate	70501
Flame detector	MZ 770 S	50001
optional	MZ 770 S with shaft	51001
optional	IRD 1010 right	16501
optional	IRD 1010 end-on	16502
optional	IRD 1010 left	16503
optional	UVD 970	16702
Support for flame detector	Holder for MZ 770 S	59100
optional	Holder M74 for IRD or UVD	59074
Connectioncable	Plug type, 3 core cable, 0.6 m with tag wire ends	7236001
Connectioncable	Plug type, 2 core cable, 0.6 m with tag wire ends	7225001

The above ordering information refers to the standard version.
Special versions are also included in our product range.

Specifications subject to change without notice

TF 974 / 976