

WINKEL Bearing axial bearing fixed Type 4.054 + AP 0

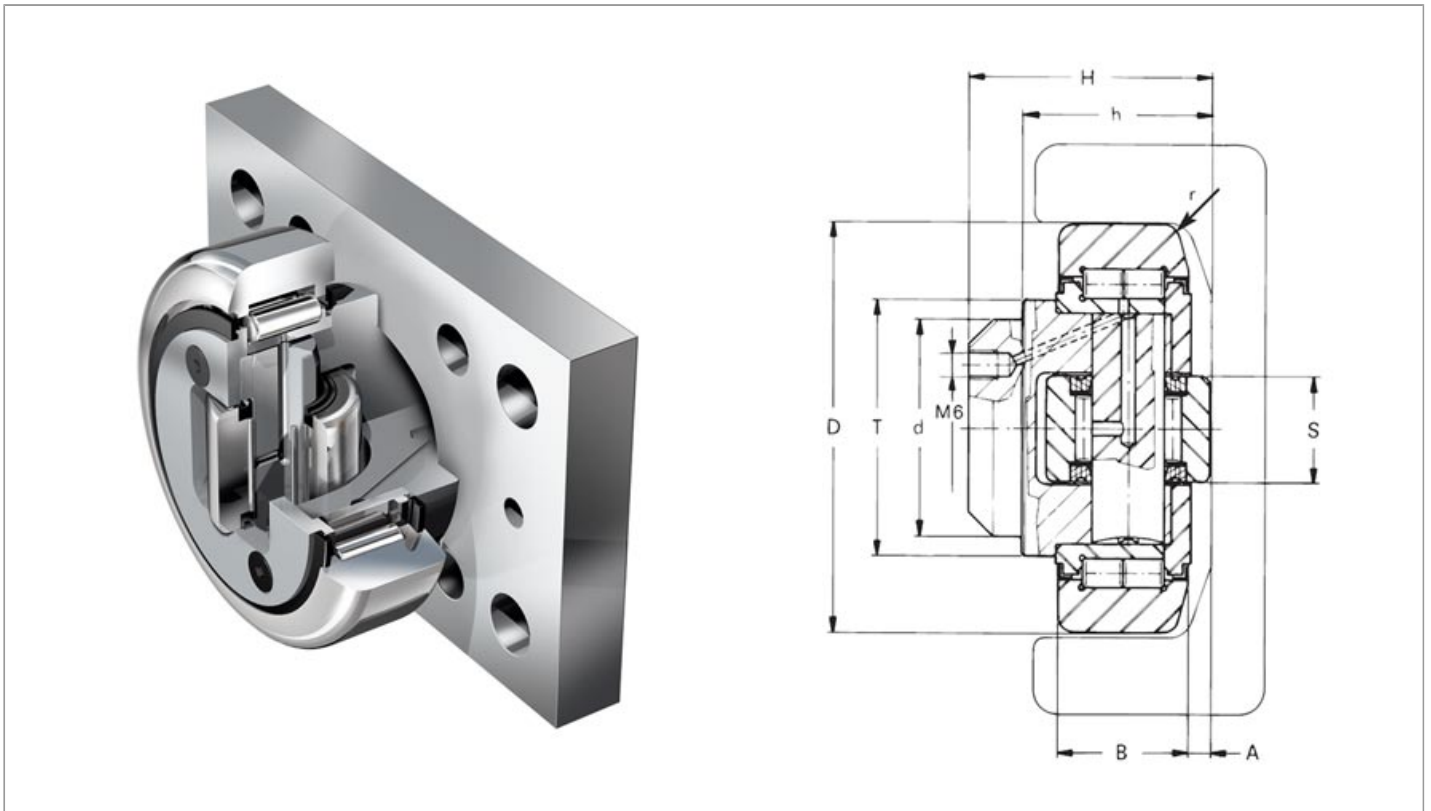

WINKEL Bearing axial bearing fixed | Article No.: 200.051.000

Technical dimensions

Type	D mm	T mm	d -0.05 mm	H mm	h mm	B mm	A mm	S mm	r mm
4.054	62.5	42	30	37.5	30.5	20	2.5	20	3

Load capacity

Type	F_R kN	F_A kN	C kN	C_0 kN	C_A kN	C_{0A} kN	r/pm max.	Weight kg	Flange plates	Profile
4.054	10,30	3,20	31,0	35,5	11	11	900	0,53	AP0	0 NbV

[Click to the product](#)

General advice

Dimensions

- For the dimension of bearing and profile, the maximum allowable load F [N] max. stat. should be confirmed.

Relubrication

- Our Winkel bearings are full complement cylindrical rollers which are lifetime lubricated for one shift and unsteady operation. Due to many years of experience we can assure you that for these kinds of use there will be no reduction of lifetime at normal applications.
- For applications such as for example in warehouses and machine halls a light surface conservation with commercial spray oil will be sufficient and in addition, a regular relubrication every 6 months.
- For extension of life-time the Winkel bearings 4.054 up to 4.063 are relubricateable. Generally, the relubrication holes are closed with threaded plugs M6. The bearings are delivered without grease nipple.

In case of special environmental conditions such as dust, incur of dirt, moisture, outdoor operations, temperatures over 40 degrees, frequent load changes (continuous operation) and heavy duty the bearings should be relubricated at least one time per month. For this we would recommend to you to use our lubrication system Winkel Combi-Lub 1 or a central lubrication system.

Bearings are lubricated with grease grade 3 (e.g. Shell Gadus S2 V100 3)

Working up

- For welding operations on WINKEL Bearings with a diameter less than 100 mm, all bearing components must be disassembled.

WINKEL Bearings with an outer diameter more than 100 mm should be welded on both sides of the bolt.

After the assembling of the bearings, or after the adjusting operation, the front side screws should be secured with loctite.

To avoid cracks in the welded joints please use welding electrodes and cored wire for unalloyed steel. For example electrode: E 42 5 B 42 H 10 according DIN EN 499. For example cored wire: T 42 4 B C 3 H5 / 7 42 4 B M 3 H5 according DIN EN 758.

- Jumbo WINKEL Bearings should be welded on both sides of the bolt.
- The guide ways in the profiles should be lightly greased and not painted.

Special designs

- Special bolts are available for WINKEL Bearings of type (PR) 4.072 (P) to (PR) 4.080 (P).

System solutions

- We construct and manufacture complete lift- and handling units according to customer needs. Constructions with CAD and a progressive production enables high flexibility in achieving complete solutions in the field of handling systems and automation.

Tolerances

- For all not tolerated dimensions counts ISO 2768 - m