

3-Component Measuring System for Cutting Force Measurement During Turning

Type 9129A...

Modular system for measurement of cutting forces when turning outside and inside diameters on turret lathes.

- Machine adapters for disk-type turrets with:
 - VDI tool holding fixtures $\varnothing 30$ mm, $\varnothing 40$ mm, $\varnothing 50$ mm
 - Coromant Capto C5, C6 clamping unit
 - Direct tool holding fixtures 20x40 mm, 25x50 mm, $\frac{3}{4}$ " x 1 $\frac{1}{2}$ ", 1" x 2"
- Tool holders for external turning tools: 20x20 mm, 25x25 mm, $\frac{3}{4}$ " x $\frac{3}{4}$ ", 1" x 1"
- Tool holders for internal turning tools: $\varnothing 25$ mm, $\varnothing 32$ mm, $\varnothing 40$ mm
- For cutting forces up to 8 kN
- Minimal temperature error

Description

The dynamometer consists of four 3-component force sensors which are mounted under high preload between the cover plate and the two lateral base plates.

Due to the special mounting of the sensors, a minimal temperature error is achieved. The forces are measured with practically no displacement. The outputs of the four integral force sensors are passed to the 9-way flange socket.

The four sensors are mounted with ground isolation. This largely avoids ground loop problems.

The dynamometer is corrosion-resistant and protected against the penetration of coolant. Used together with connecting cables Type 1687B.../Type 1689B..., the dynamometer is protected to IP67.

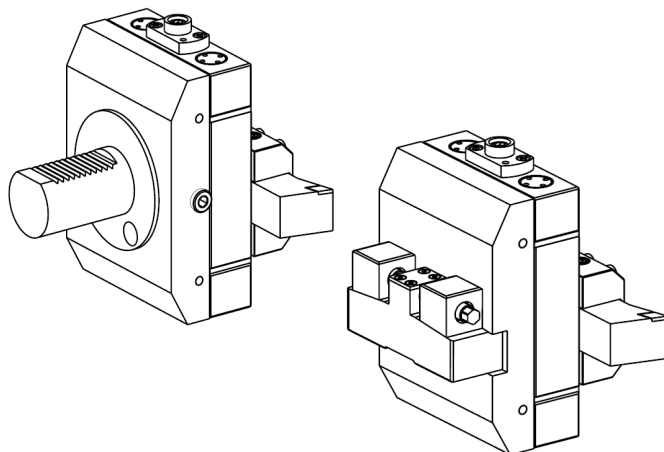

Fig. 1: Dynamometer Type 9129AA with machine adapter Type 9129AB40 (left) and Type 9129AD25 (right) and tool holder Type 9129AE25



Technical Data

Max. permitted measuring range (Type 9129AA mounted with adapter Type 9129AB50 or 9129AC6 or 9129AD25 or tool adapter Type 9129AE25, L = 35 mm)	F_x, F_z	kN	-5 ... 5
	F_y	kN	-8 ... 8
Permitted measuring ranges (Type 9129AA mounted with remaining adapters)	F_x, F_y, F_z		see Fig. 1
Calibrated measuring range	F_x, F_z	kN	0 ... 5
	F_y	kN	0 ... 8
Calibrated partial meas. range	F_x, F_z	kN	0 ... 0,5
	F_y	kN	0 ... 0,8

Dynamometer Type 9129AA is calibrated with mounted machine adapter Type 9129AB50, tool holder Type 9129AE25 and dummy tool with 35 mm overhang.

9129A_000-710e-06.14

Further Technical Data

Overload	F_x, F_y, F_z	%	20
Threshold		N	<0,01
Sensitivity (nominal)	F_x	pC/N	≈-8
	F_y	pC/N	≈-4,1
	F_z	pC/N	≈-8
Sensitivity deviation dependent on the machine adapter	F_x, F_y, F_z	%	≤±1
Linearity, all ranges	F_x, F_y, F_z	±%FSO	≤±0,3
Hysteresis, all ranges	F_x, F_y, F_z	%FSO	≤0,3
Crosstalk	$F_z \rightarrow F_x, F_y$	%	≤±3
	$F_x \leftrightarrow F_y$	%	≤±3
	$F_x, F_y \rightarrow F_z$	%	≤±3
Natural frequency *	$f_n(x)$	kHz	≈1,5
	$f_n(y)$	kHz	≈1,5
	$f_n(z)$	kHz	≈2,5
Operating temperature range		°C	0 ... 70
Capacitance	F_x, F_y, F_z	pF	≈180
Insulation resistance		Ω	>10 ¹³
Ground isolation		Ω	>10 ⁸
Protection class EN60529			IP67
Weight	Dynamometer	kg	3,2
	Cover plate	kg	2,0
Mounting surface		mm	90x105
Connection			Fischer flange 9-pole neg.

* Type 9129AA with mounted machine adapter Type 9129AB40, tool holder Type 9129AE25, less dummy tool.

Application

- Measurement of the three cutting forces F_c, F_f, F_p while turning outside and inside diameters on lathes with turret-type tool heads.
- Type 9129AA dynamometer alone is also suitable as a multicomponent force measuring device for general force measurements. It can be separately mounted without accessories directly on a flat base plate (table). (See data sheet for Type 9129AA 9129AA_000-709)

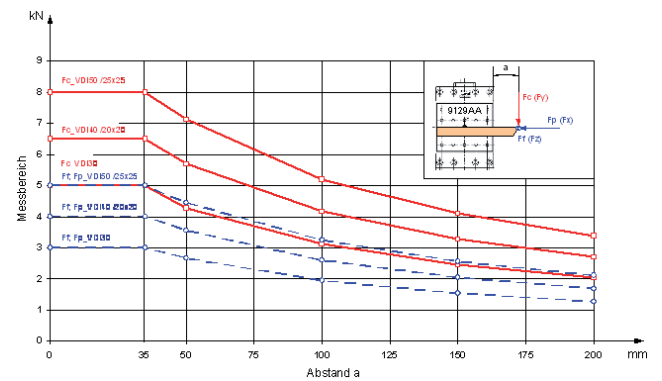

Fig. 2: Max. measuring ranges of Type 9129A... measuring system for different machine adapters depending on the tool overhang (all forces can occur simultaneously)

Mounting

The dynamometer is mounted on the tool holding fixture of the disk-type turret using a machine adapter. Machine adapters for current tool holding fixture systems are offered as accessories. The tool adapter mounted on the mounting plate of the dynamometer accepts the desired lathe tool. Tool adapters for current sizes of external and internal turning tools are available. On inclined bed machines with two turret disks, the measuring system can be mounted above as well as below the workpiece. The measuring system components are designed so that the position of the cutting angle always lies at the height of the axis of rotation (workpiece center) regardless of the mounting orientation.

9129A_000-710e-06.14

Typical Design Variants

Example 1

Axially mounted dynamometer for turning the outside diameter with machine adapter Type 9129AB... (VDI tool holding fixture) and tool holder Type 9129AE... .

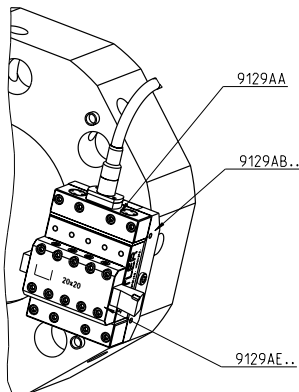

Example 2

Axially mounted dynamometer for turning the outside diameter with machine adapter Type 9129AD... (direct tool holding fixture) and tool holder Type 9129AE... .

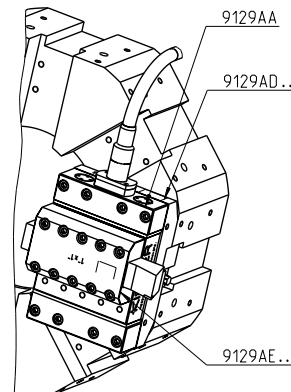

Example 3

Radially mounted dynamometer for turning the inside diameter with machine adapter Type 9129AB... (VDI tool holding fixture) and tool holder for Type 9129AF40 boring bars.

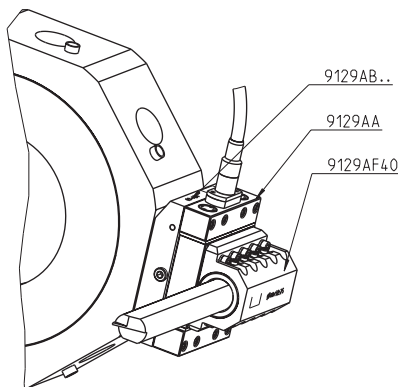

Example 4

Radially mounted dynamometer for turning the inside diameter with special intermediate plate adapted to the interface of the turret disk (by the customer) and tool holder for Type 9129AF40 boring bars.

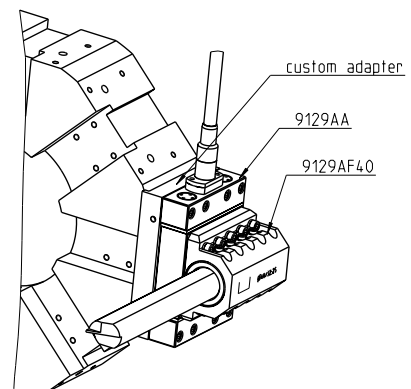

Example 5

As example 1 but with additional swarf shield mounted.

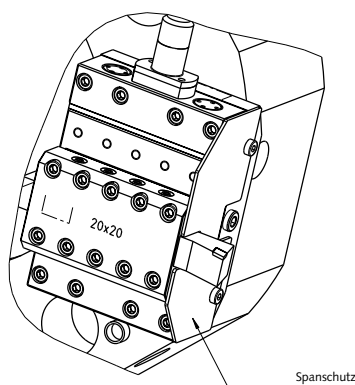

9129A_000-710e-06.14

Dimensions

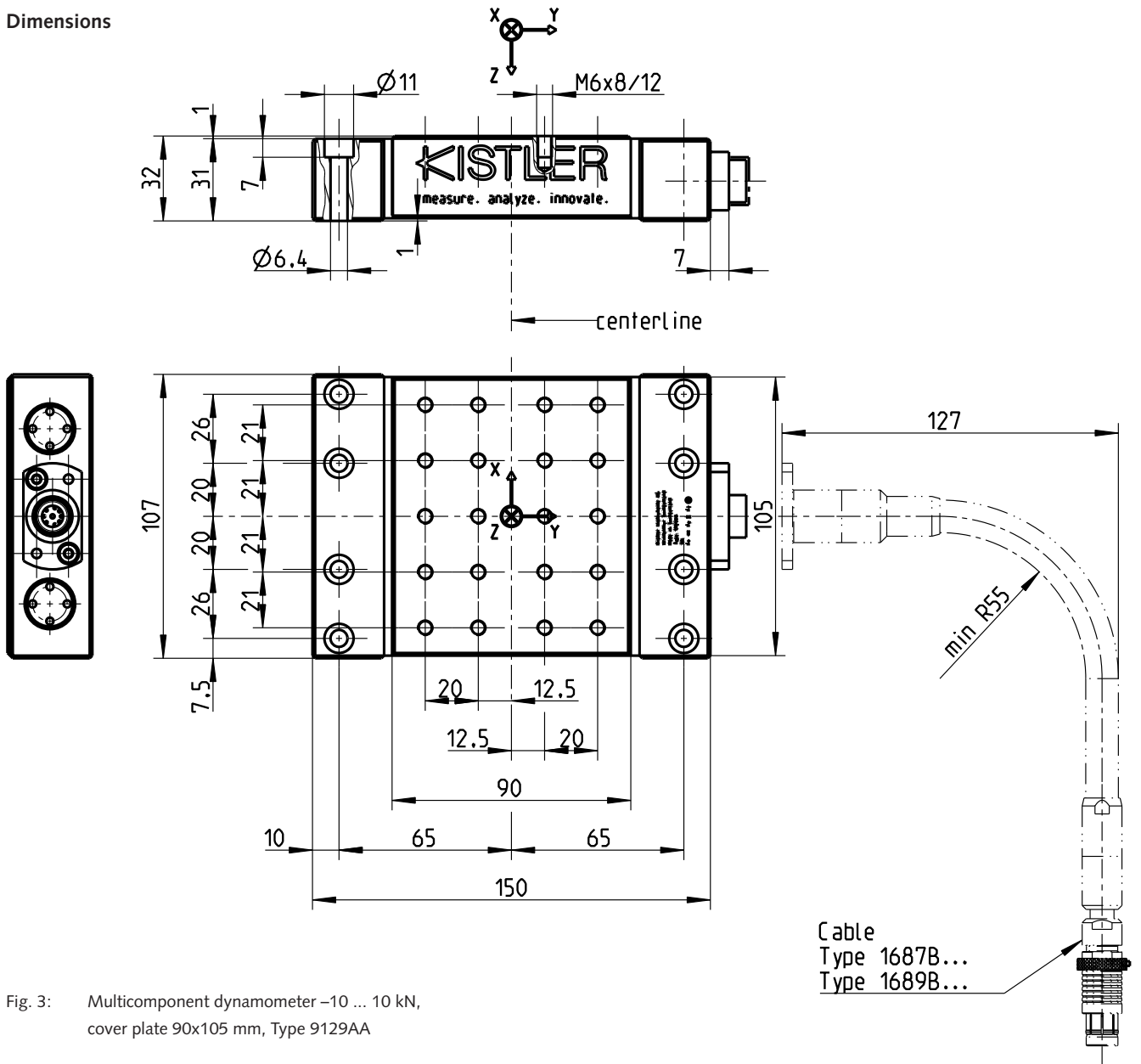

Fig. 3: Multicomponent dynamometer –10 ... 10 kN,
cover plate 90x105 mm, Type 9129AA

Pin allocation

Pin No.	Output signals
1	Ground
2	F _x
3	–
4	F _y
5	–
6	F _z
7	–
8	–
9	–

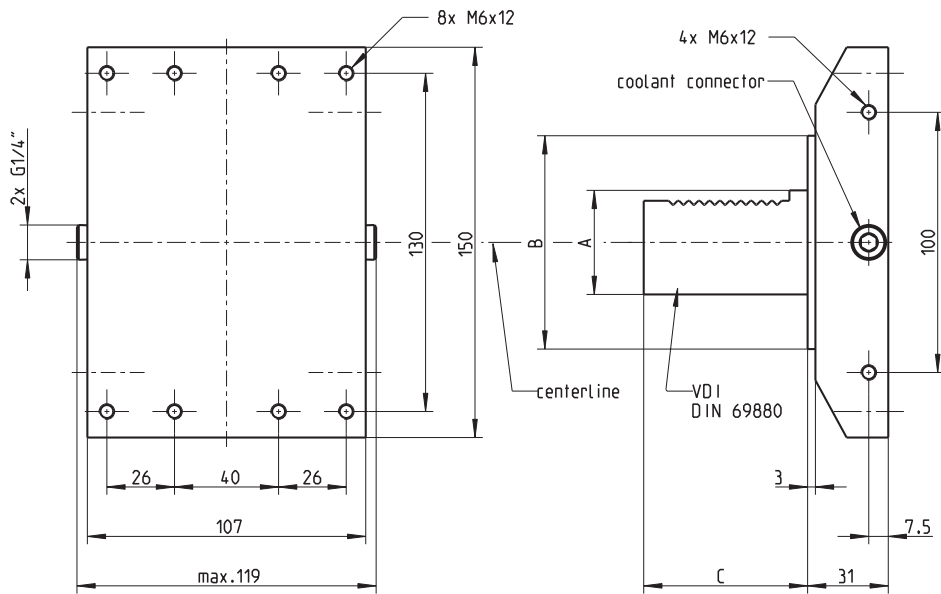

Fig. 4: Machine adapter with straight shank for disk-type turret with VDI tool holding fixture Type 9129AB...

Type	A	B [mm]	C [mm]	Weight [g]
9129AB30	VDI 30	67	55	≈3 460
9129AB40	VDI 40	82	63	≈3 870
9129AB50	VDI 50	97	78	≈4 400

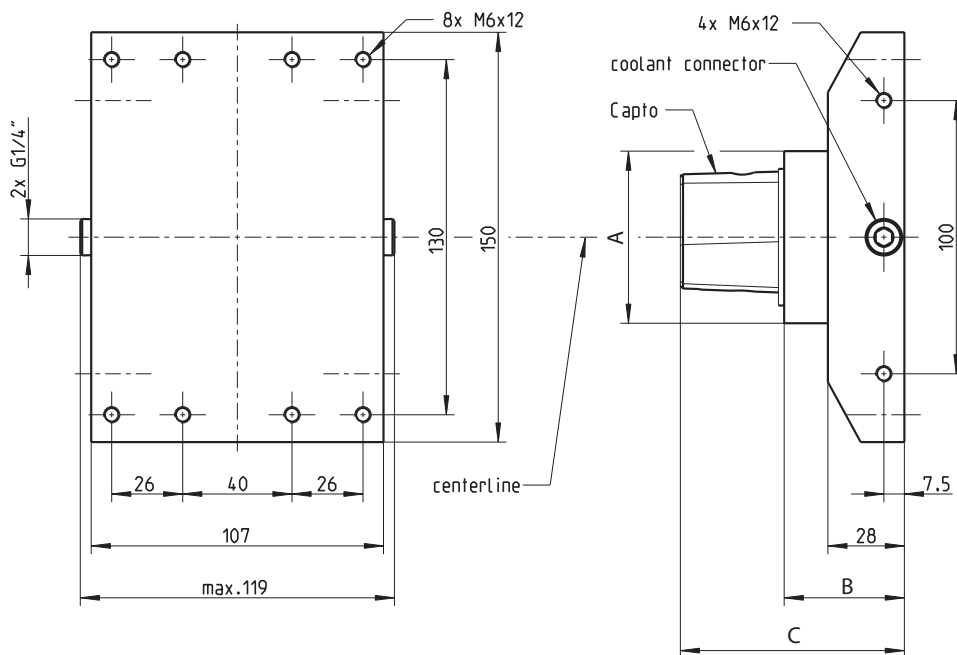

Fig. 5: Machine adapter with Capto C... for disk-type turret with Coromant Capto clamping unit, Type 9129AC...

Type	Capto Type	A [mm]	B [mm]	C [mm]	Weight [g]
9129AC5	C5	50	44	74	≈3 460
9129AC6	C6	63	44	82	≈3 808
9129AC8	C8	80	65	113	≈5 200

9129A_000-710e-06.14

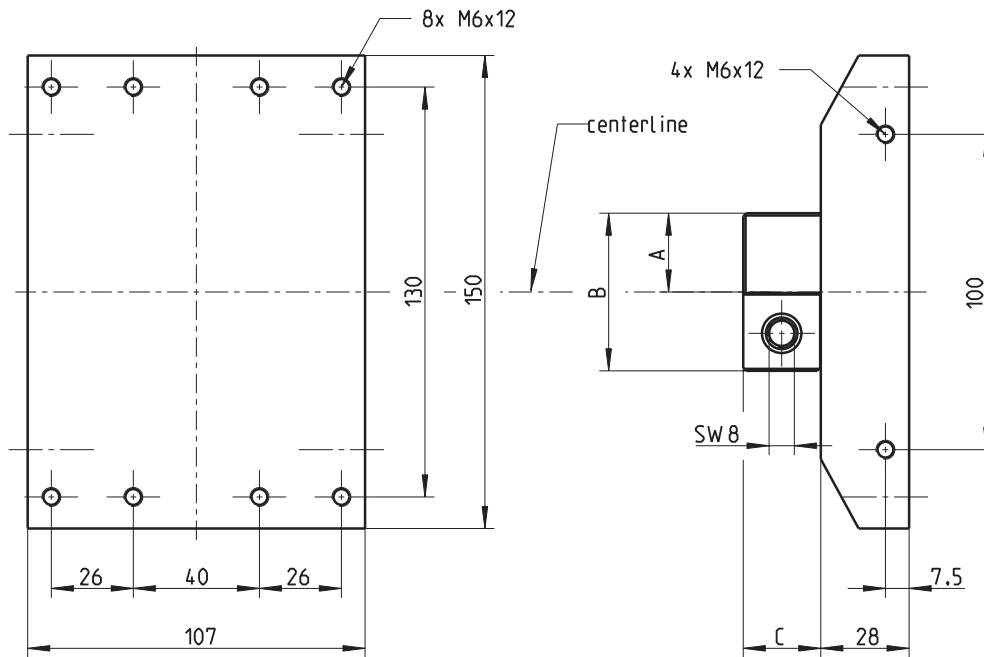

Fig. 6: Machine adapter with clamping wedge for disk-type turrets with direct tool holding fixture, Type 9129AD...

Type	A [mm]	B [mm]	C [mm]	Weight [g]
9129AD20	20	40	18,8	≈3 660
9129AD25	25	50	24,8	≈3 960
9129AD0,75	¾"	1½"	18,8	≈3 635
9129AD1	1"	2"	24,8	≈3 970

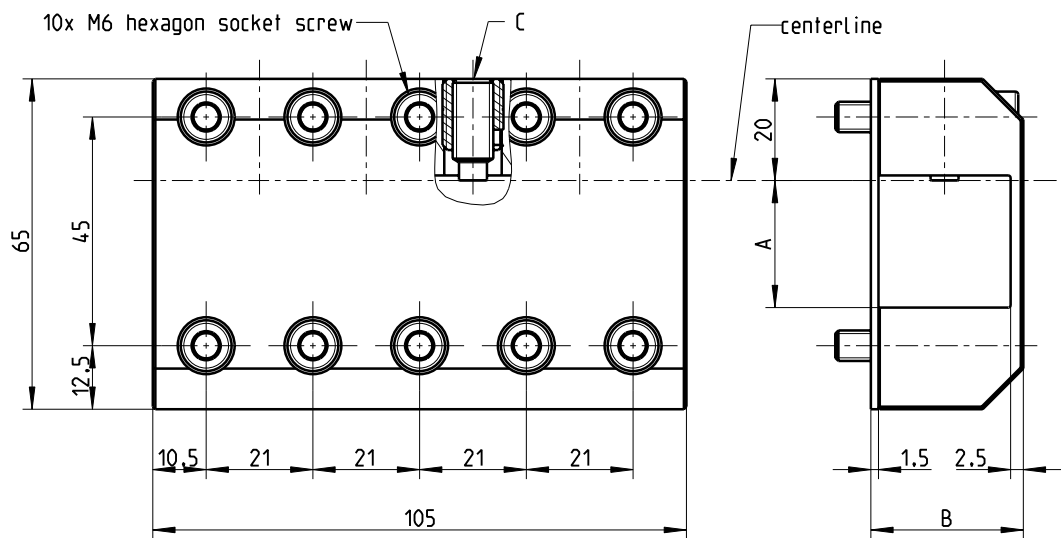

Fig. 7: Tool holder for lathe chisel for axially mounted dynamometer, Type 9129AE...

Type	A [mm]	B [mm]	C [mm]	Weight [g]
9129AE20	20	25	SW 3	≈430
9129AE25	25	30	SW 4	≈490
9129AE0,75	¾" (19,05)	24,05	SW 3	≈455
9129AE1	1" (25,4)	30,4	SW 4	≈490

9129A_000-710e-06.14

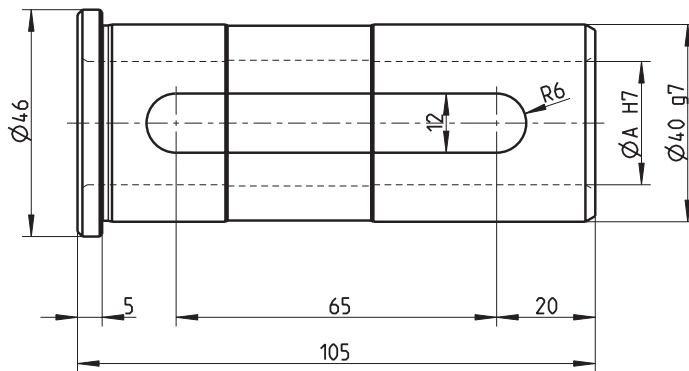
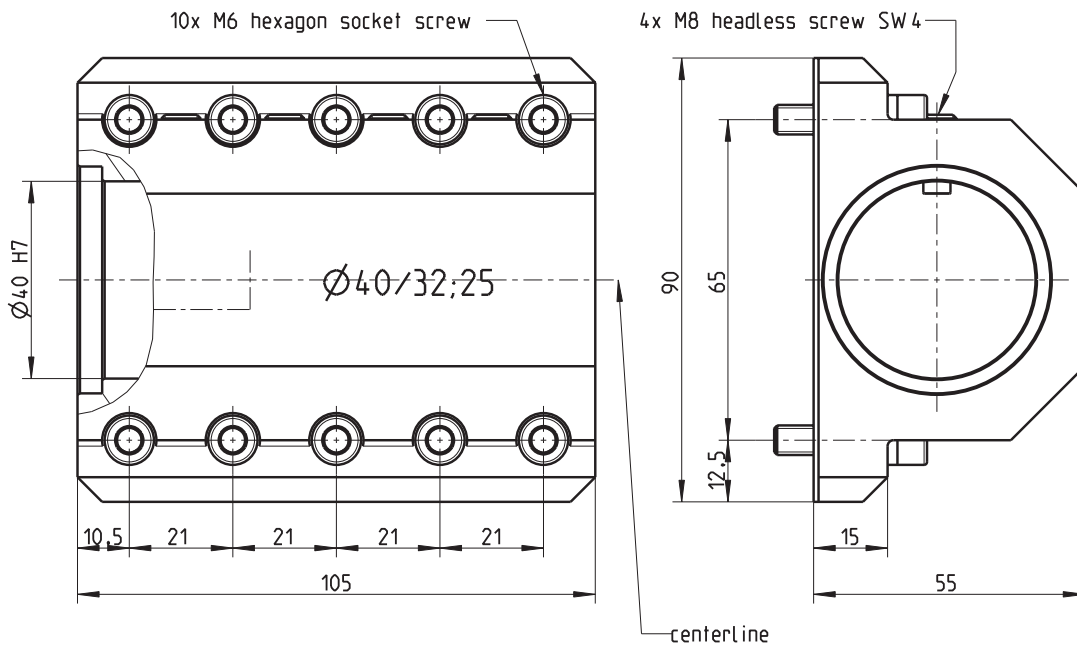

Fig. 8: Tool holder for boring bars up to $\varnothing 40$ mm for radially mounted dynamometer with reducing bushings $\varnothing 40/32$ mm, $\varnothing 40/25$ mm, Type 9129AF40

$\varnothing A$ [mm]	Reducing bushing	Item No.	Weight bushing [g]	Weight [g]
40	none	-	0	≈ 630
32	$\varnothing 40/32$	3.710.191	122	≈ 755
25	$\varnothing 40/25$	3.710.192	205	≈ 840

Processing the Measurement Signals

Charge amplifier channels are also needed to build a complete measuring system. These convert the measurement signal into an electrical voltage. The measured value is exactly proportional to the force acting.

The multichannel charge amplifier Type 5070A... has been specially developed for multicomponent force measurement systems.



Fig. 9: Multichannel charge amplifier Type 5070A...

9129A_000-710e-06.14

Measuring Chain

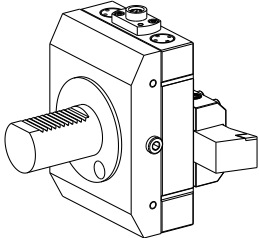
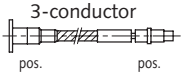
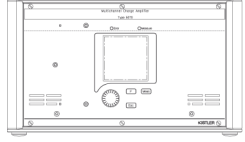
3-component measuring system Type 9129A...	Connecting cable ¹⁾	Multichannel charge amplifier ²⁾	Measured value
	Type 1687B.../1689B... 	Type 5070Ax01xx 	F_x F_y F_z

¹⁾ see data sheet: Cables for multicomponent force sensors, dynamometers and force plates 1687B_000-545e

²⁾ see data sheet: Multichannel charge amplifier for multicomponent force measurement 5070A_000-485e

Measuring System Components

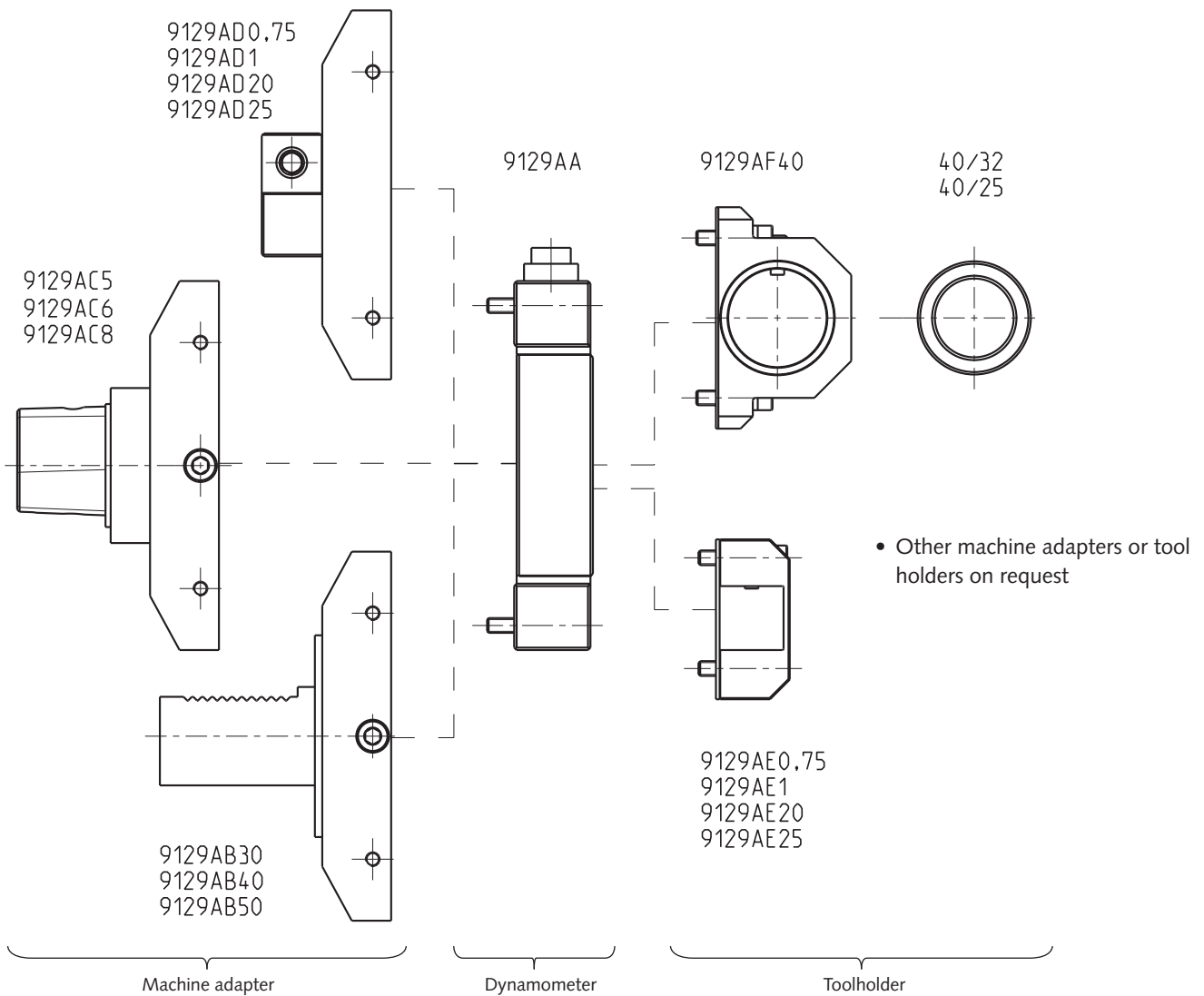

9129A_000-710e-06.14

Fig. 10: Configuration of standard components

Ordering Key

- Multicomponent dynamometer up to 10 kN, cover plate 90x105 mm
Accessories included:
– Mounting screws M6x35 (8 items)

- Machine adapter with straight shank ø30 mm for disk-type turret with VDI tool holding fixture, DIN 69880-30x55 for Type 9129AA

- Machine adapter with straight shank ø40 mm for disk-type turret with VDI tool holding fixture, DIN 69880-40x63 for Type 9129AA

- Machine adapter with straight shank ø50 mm for disk-type turret with VDI tool holding fixture, DIN 69880-50x78 for Type 9129AA

- Machine adapter with Capto C5 for disk-type turret with Coromant Capto clamping unit for Type 9129AA

- Machine adapter with Capto C6 for disk-type turret with Coromant Capto clamping unit for Type 9129AA

- Machine adapter with Capto C8 for disk-type turret with Coromant Capto clamping unit for Type 9129AA

- Machine adapter with clamping wedge ¾"x1½" for disk-type turret with direct tool holding fixture for Type 9129AA

- Machine adapter with clamping wedge 1"x2" for disk-type turret with direct tool holding fixture for Type 9129AA

- Machine adapter with clamping wedge 20x40 mm for disk-type turret with direct tool holding fixture for Type 9129AA

- Machine adapter with clamping wedge 25x50 mm for disk-type turret with direct tool holding fixture for Type 9129AA

Other machine adapters and tool holders on request.

Type/Art. No.

9129AA

65012770

9129AB30

9129AB40

9129AB50

9129AC5

9129AC6

9129AC8

9129AD0,75

9129AD1

9129AD20

9129AD25

- Tool holder for lathe chisel ¾" x ¾" for axially mounted dynamometer for Type 9129AA
Accessories included:

- Hex socket head cap screw M6x22 (10 items)
- Swarf shield 20

- Tool holder for lathe chisel 1"x1" for axially mounted dynamometer for Type 9129AA
Accessories included:

- Hex socket head cap screw M6x30 (10 items)
- Swarf shield 25

- Tool holder for lathe chisel 20x20 mm for axially mounted dynamometer for Type 9129AA
Accessories included:

- Hex socket head cap screw M6x22 (10 items)
- Swarf shield 20

- Tool holder for lathe chisel 25x25 mm for axially mounted dynamometer for Type 9129AA
Accessories included:

- Hex socket head cap screw M6x30 (10 items)
- Swarf shield 25

- Tool holder for boring bars up to ø40 mm for radially mounted dynamometer for Type 9129AA
Accessories included:

- Hex socket head cap screw M6x22 (10 items)
- Reducing bushing ø40/32
- Reducing bushing ø40/25

- Connecting cable, 3-wire with flexible metal sheath

- Connecting cable, 3-wire with flexible sheath

- Connecting cable, 3-wire with metal flexible sheath and right-angle connector

- Packing and carrying case for assembled measuring system

9129AE0,75

65013776

65006803

9129AE1

65013777

65006804

9129AE20

65013776

65006803

9129AE25

65013777

65006804

9129AF40

65013776

65006801

65006802

1687B5

1687BQ02sp

1689B5

9129AZ1

9129A_000-710e-06.14